

"Wireless World"
Iiffe Electrical Publications Ltd.,
Dorset House, Stamford Street,
London, S.E.1

Managing Director:

W. E. MILLER, M.A., M.I.E.R.E.

Editor-in-Chief:

W. T. COCKING, M.I.E.E.

Editor:

H. W. BARNARD

Technical Editor:

T. E. IVALL

Editorial:

D. C. ROLFE

G. B. SHORTER, B.Sc.

Drawing Office:

H. J. COOKE

Production:

D. R. BRAY

Advertisements:

G. BENTON ROWELL

(Manager)

J. R. EYTON-JONES

© Iiffe Electrical Publications Ltd., 1965. Permission in writing from the Editor must first be obtained before letterpress or illustrations are reproduced from this journal. Brief extracts or comments are allowed provided acknowledgement to the journal is given.

VOLUME 71 No. 8

PRICE: 3s.

FIFTY-FIFTH YEAR
OF PUBLICATION

Wireless World

ELECTRONICS, TELEVISION, RADIO, AUDIO

SEPTEMBER 1965

- 419 Editorial Comment
- 420 A Simple Transistor F.M. Tuner *by J. C. Hopkins*
- 422 Books Received
- 423 Medical Instrumentation *by V. K. Zworykin*
- 426 Electronics for "Mediator"
- 430 Switched Thyristor Voltage Regulator *by F. Butler*
- 432 H.F. Predictions—September
- 433 World of Wireless
- 435 Personalities
- 437 Demonstration of Oscillatory Action *by T. Palmer*
- 438 Conferences and Exhibitions
- 439 Letters to the Editor
- 442 Semiconductor Detectors for Nuclear Radiation *by J. B. Dance*
- 449 News from Industry
- 450 Experimental Thyristor Control Circuits—2 *by N. M. Morris*
- 455 Electronic Laboratory Instrument Practice—9 *by T. D. Towers*
- 460 Commercial Literature
- 462 New Products
- 468 Real and Imaginary *by "Vector"*

PUBLISHED MONTHLY (4th Monday of preceding month). Telephone: Waterloo 3333 (70 lines). Telegrams/Telex: Wiworld Iiffepres 25137 London. Cables: "Ethaworld, London, S.E.1." Annual Subscriptions: Home £2 6s 0d. Overseas: £2 15s 0d. Canada and U.S.A. \$8.00. Second-class mail privileges authorised at New York N.Y. BRANCH OFFICES: BIRMINGHAM: King Edward House, New Street, 2. Telephone: Midland 7191. BRISTOL: 11, Marsh Street, 1. Telephone: Bristol 21491/2. COVENTRY: 8-10, Corporation Street, Telephone: Coventry 25210. GLASGOW: 123, Hope Street, C.2. Telephone: Central 1265-6. MANCHESTER: 620, Deansgate, 3. Telephone: Blackfriars 4412. NEW YORK OFFICE U.S.A.: 111 Broadway, 6. Telephone: Digby 9-1197.



By foreseeing the needs of the public; by anticipating the practical requirements of setmakers; by helping to solve the problems of service engineers and dealers; by building reliability and performance into every product they make, **MULLARD** have created a unique business philosophy.... in a word **INTRINSICALITY.**



WW-114 FOR FURTHER DETAILS.

Wireless World

ELECTRONICS, TELEVISION, RADIO, AUDIO

Who Designs Systems — and How Well?

APPOINTMENTS and situations-vacant advertisements, some in large display panels, are making us aware of a new breed of specialist called a systems engineer. Sometimes he is given a specific “discipline”—telephone, computer, avionics—but often just as a “systems engineer.” From the blurb in the advertisement it appears that the wanted engineer is mainly an electronics man, although he is not to be concerned with the detailed design of specific pieces of equipment. He apparently has to build up existing pieces of equipment or known techniques into systems primarily for the transmission, processing and presentation of information. On his work may depend the safety of human lives—as for example in the new National Air Traffic Control Scheme described in this issue, and a plane’s automatic landing system—or the operation of vast industrial plants.

Where do these systems engineers come from? How are they trained and how do they get their experience? These questions ought to be examined, as it does not appear that there is any established machinery for training them. One might go so far as to say that they are virtually amateurs, picking up expertise as they go along.

An important aspect of systems engineers’ work is reliability. In electronics and communications we tend to think of reliability mainly in terms of immunity from breaking down of components or equipment, and of circuit designs having good safety factors, etc. These things are all necessary of course in the individual parts of systems, but are not enough in themselves to ensure system reliability.

For example, a system can fail even though all the electronics are working perfectly. In an information processing system a situation could arise where more digits are being fed into a store than it will actually hold: the capacity of the store is exceeded and there is consequently a loss of accuracy or a complete breakdown.

Redundancy, therefore, plays a vital rôle in achieving reliability in the design of systems, as indeed is the case with animal nervous systems so that part of the “hardware” can be damaged and yet the overall system carries on. An example of a system achieving reliability through redundancy is the automatic landing system being designed for the Trident and other aircraft. This is a triplicated system with a majority vote scheme for ensuring correct operation. If two out of the three autopilots give the same output it can be assumed that that output is the correct one. If only two autopilots were installed, and they gave different outputs, how would one know which was correct?

Redundancy design techniques are a complex of economics, logic, statistics (including probability theory), information theory, etc., and the systems engineer, while being at heart an electronics man, must, it would seem, be a “generalist” rather than a “specialist.”

VOL 71 NO 9
SEPTEMBER 1965

A Simple Transistor F.M. Tuner

DESIGN USING A PULSE DISCRIMINATOR AND AN LC-TUNED LOCAL OSCILLATOR

By J. C. HOPKINS,* B.Sc., Grad.I.E.E., A.Inst.P

FOLLOWING the publication of the "Wireless World F.M. Tuner" (July 1964) some interest seems to have been aroused again in the pulse counting type of receiver. P. J. Baxandall¹ has also pointed out that a simplified version using an LC-tuned local oscillator, and employing valves, had been designed and built by him some years ago. The following is a description of a transistor tuner designed along similar lines.

R.F. and mixer stages

These are shown in Fig. 1. The aerial is coupled *via* a coaxial cable to the emitter of Tr_1 which acts as a common-base amplifier. The operating current of the stage is set at about 0.7 mA and this yields an input impedance which approximately matches the input cable. Since this impedance is somewhat inductive at 90 Mc/s, it can be rendered resistive by simply adding the tuning capacitor C_2 .

The r.f. stage is capacitively coupled to the base of Tr_2 which acts as a self-oscillating mixer. As suggested by Baxandall, a 45 Mc/s local oscillator frequency was tried, the second harmonic of this beating with the signal to produce the required i.f. (at about 200 kc/s.). However this was found to produce a high level of second harmonic signal at the aerial terminals and so it was decided to employ a 30 Mc/s oscillator and tolerate the lower value of conversion gain produced. As a result, the gain of the r.f. stage slightly more than compensates for the loss incurred in the mixer! Nevertheless an overall sensitivity of the order of 100 μ V is achieved.

The oscillator configuration employed is a modified Clapp type, the transistor operating in common-base mode so far as this action is concerned. The base is connected to earth *via* L_3 and C_7 which is broadly series resonant near 30 Mc/s. This reduces the fundamental component of the local oscillator signal fed back over the r.f. stage. A rejector circuit (L_2, C_6) for 60 Mc/s is also included. At the same time, these components are chosen so that at 90 Mc/s they balance the capacitive part of the input impedance of Tr_2 , thus assisting the signal transfer from the r.f. stage. The oscillator frequency is stabilized against ambient temperature changes by using a resistive biasing network which renders the change in collector current with temperature quite small and the final compensation is achieved by giving the capacitor C_{11} a negative temperature coefficient. This is achieved by the parallel combination of a high-stability capacitor with a ceramic type having a coefficient of -750 p.p.m. per $^{\circ}$ C.

Intermediate frequency signals are taken at low impedance from the emitter of Tr_2 *via* R_{10} and the low pass filter L_5, C_{16}, L_6 . The latter gives a fairly level response up to about 350 kc/s but attenuates at higher frequencies quite sharply, the mutual inductance of the two windings series resonating at about 2 Mc/s with C_{16} . This gives good rejection of the adjacent f.m. channels which produce beat frequencies in a region where the gain of the i.f. amplifier is still significant. It was found that a standard 470 kc/s i.f. transformer could be used to produce this filter, the usual winding inductances (without

*Bristol College of Science and Technology.

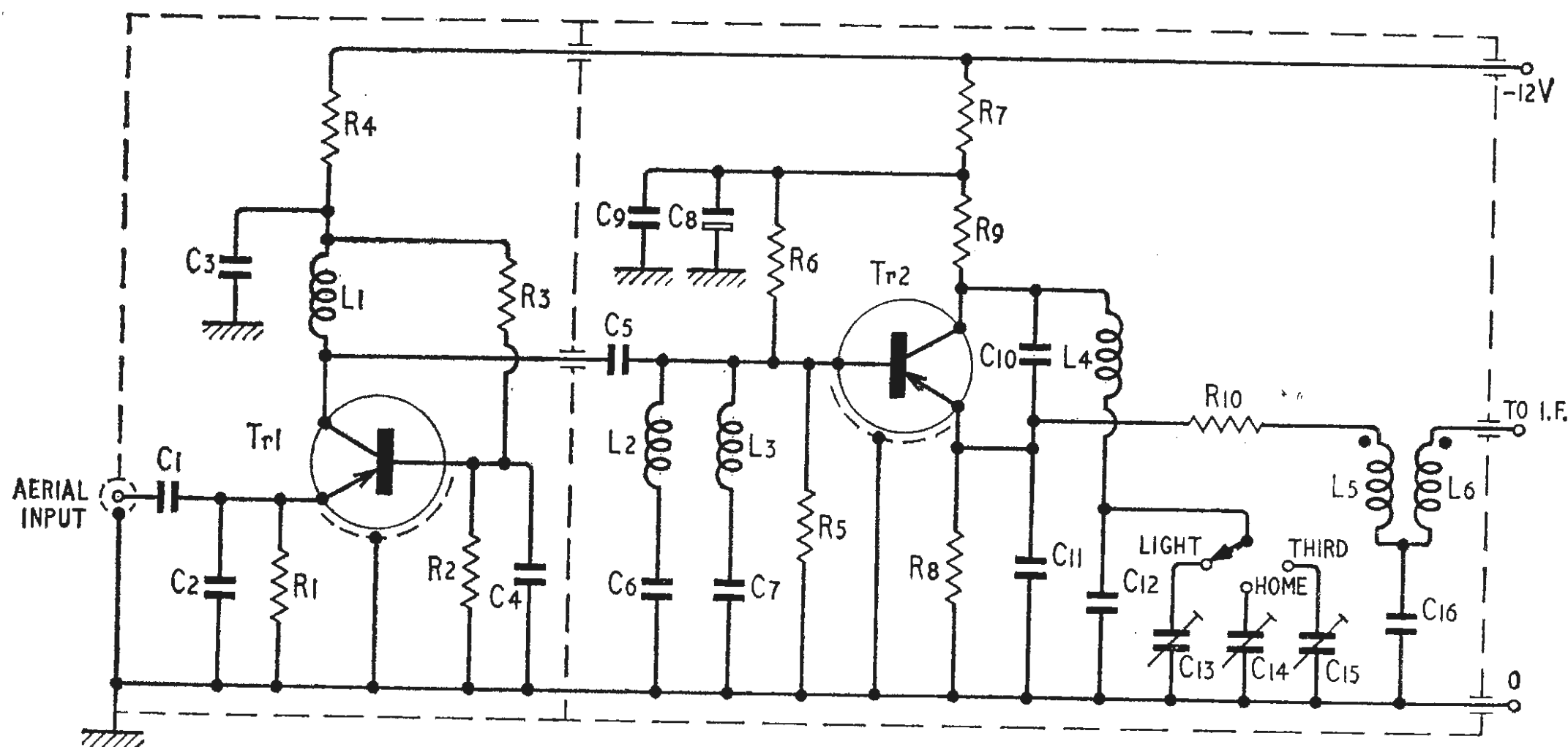
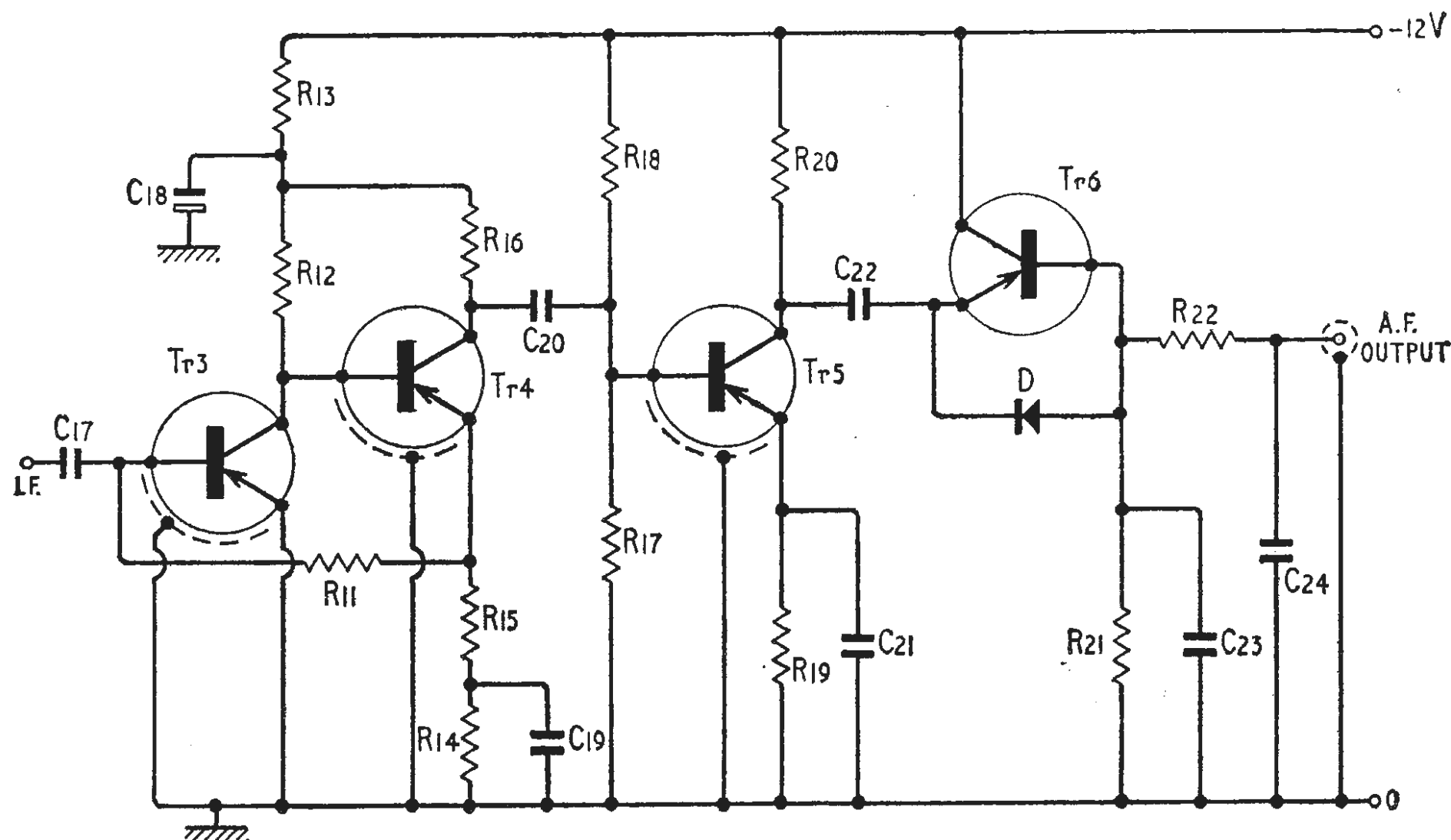

Fig. 1. R.F. and mixer stages.

Fig. 2. I.F. and discriminator stages.



the normal tuning capacitors) and the coupling between windings being quite suitable for the job in hand.

I.F. and discriminator sections

These are shown in Fig. 2. Tr_3 and Tr_4 form a directly coupled pair with feedback both at d.c. (to achieve

temperature stabilization) and at signal frequency where it usefully levels the frequency response and reduces gain changes produced by the different samples of OC171.

Tr_5 acts as final amplifier stage and is over-driven to produce a limiting action. A rectangular wave of approximately 11V pk-pk appears at the collector, the limiting

LIST OF COMPONENTS

Resistors

R_1	1k Ω	R_{12}	10k Ω
R_2	1k Ω	R_{13}	1k Ω
R_3	10k Ω	R_{14}	680 Ω
R_4	1k Ω	R_{15}	100 Ω
R_5	3.9k Ω	R_{16}	6.8k Ω
R_6	10k Ω	R_{17}	3.3k Ω
R_7	1k Ω	R_{18}	27k Ω
R_8	2.2k Ω	R_{19}	470 Ω
R_9	2.2k Ω	R_{20}	2.7k Ω
R_{10}	2.2k Ω	R_{21}	3.9k Ω
R_{11}	39k Ω	R_{22}	15k Ω ($\pm 5\%$)

All resistors $\frac{1}{2}$ W, $\pm 10\%$, carbon, unless otherwise stated.

Capacitors

C_1	0.001 μ F, disc ceramic.
C_2	4.7pF $\pm 10\%$, ceramic.
C_3	0.001 μ F, disc ceramic.
C_4	0.001 μ F, disc ceramic.
C_5	3.3pF $\pm 10\%$, ceramic.
C_6	10pF $\pm 1\%$, silvered mica.
C_7	25pF $\pm 1\%$, silvered mica.
C_8	10 μ F, 15V sub-miniature electrolytic.
C_9	0.001 μ F, disc ceramic.
C_{10}	220pF $\pm 1\%$, silvered mica.
C_{11}	218pF: 68 pF $\pm 1\%$, silvered mica, in parallel with 150pF $\pm 10\%$, ceramic.
C_{12}	68pF $\pm 1\%$, silvered mica.
C_{13}	3-30pF concentric trimmer.
C_{14}	
C_{15}	
C_{16}	624pF: 68pF in parallel with 556pF, both $\pm 1\%$, silvered mica.
C_{17}	0.01 μ F $\pm 20\%$, 250V polyester.
C_{18}	1 μ F, 15V sub-miniature electrolyte
C_{19}	0.1 μ F $\pm 20\%$, 250V polyester.
C_{20}	0.01 μ F $\pm 20\%$, 250V polyester.
C_{21}	0.1 μ F $\pm 20\%$, 250V polyester.
C_{22}	68pF $\pm 1\%$, silvered mica.
C_{23}	2700pF $\pm 1\%$, silvered mica.
C_{24}	3600pF $\pm 1\%$, silvered mica.

Inductors

- L_1 6 turns 22 swg (enamel) $\frac{1}{2}$ in dia., spaced to about $\frac{1}{2}$ in long (self supporting).
- L_2 13 turns 26 swg (enamel), close wound on 1W carbon resistor of high value ($\frac{7}{8}$ in dia.).
- L_3 19 turns 26 swg (enamel), close wound as for L_2 .
- L_4 8 turns 18 swg (enamel) $\frac{1}{2}$ in dia. close wound (self supporting).
- L_5, L_6 Standard 470 kc/s i.f. transformer (Radiospares) with dust cores removed.

Connect "start" ends of windings together.

Switch

Single pole, 3-way wafer switch (Radiospares).

Semiconductor devices

- Tr_1 - Tr_5 OC171.
- Tr_6 OC41.
- D OA10.

Notes

- (a) Total consumption: about 8mA at 12V.
 - (b) The supply voltage should preferably be held to about 12 ± 1 V. This could most conveniently be derived from the mains and roughly stabilised with a Zener diode to achieve the value required.
 - (c) R_{14} (nominally 680 Ω) may require adjustment with some transistor pairs (Tr_3, Tr_4). A value should be chosen which sets the collector voltage of Tr_4 at between 5 and 7V negative w.r.t. earth.
 - (d) A modification of the discriminator circuit values will enable the tuner to feed about 1V a.f. into loads of 1M Ω or greater. This is done by adopting the following component values:—
 - R_{21} 39k Ω , $\frac{1}{2}$ W, $\pm 10\%$ carbon.
 - R_{22} 150k Ω , $\frac{1}{2}$ W, $\pm 5\%$ carbon.
 - C_{23} 270pF, $\pm 1\%$ silvered mica.
 - C_{24} 330pF, $\pm 1\%$ silvered mica.
- The modification is useful for feeding some valve power amplifiers without the need for an intermediate pre amplifier.

action being sufficiently good up to 350 kc/s to achieve excellent discriminator action.

The discriminator itself is a transistor pump². This is a modified version of the familiar diode pump which gives improved linearity at the higher output levels. The audio output is finally taken *via* R_{22} and C_{24} which provide the required de-emphasis characteristic. An audio output of about 100 mV (r.m.s.) for a deviation of ± 75 kc/s, can be delivered into loads of 100 k Ω or greater. Where this is done with a coaxial cable, care should be taken to see that the length does not exceed about 10ft.

Construction

This is not unduly critical but the whole must of course be enclosed in a screened aluminium box and the r.f., mixer and i.f. sections screened from each other.

The discriminator and i.f. stages are assembled on an insulating board using conventional wiring techniques. (A printed wiring board would probably also be suitable). The r.f. and mixer stages are most conveniently assembled on paxolin insulated tag strips screwed to the aluminium housing, the most suitable place for the low-pass filter seems to be within the mixer compartment, the normal screening can of the i.f. transformer being removed and the coil former mounted directly on the chassis.

Setting up

Aerial.—The tuner should preferably be fed from a dipole aerial proportioned for Band II operation. This should yield an adequate signal for correct operation for

field strengths down to 250 μ V/m, if care is taken with the aerial installation. In areas of very low field strength a multi-element array will be necessary.

Oscillator.—The main adjustment required is that of setting the local oscillator frequency. This is most conveniently done by feeding in 90 Mc/s signals from a signal generator (say about 500 μ V r.m.s.) into the aerial terminals and adjusting the self supporting coil L_4 until the whole range can be tuned with the trimmers C_{13} , C_{14} , C_{15} . L_1 should also be adjusted to peak at about mid-band, i.e. 94 Mc/s. Final oscillator frequency adjustment can easily be done on a signal, if a high-resistance voltmeter is arranged to read the mean d.c. signal appearing at the a.f. output socket. The appropriate trimmer is first adjusted to give a low intermediate frequency—as indicated by a “null” reading on the voltmeter—and then the oscillator frequency is moved to one side of this setting, to produce a voltmeter reading of 0.4 V. This will give a mean i.f. of about 180 kc/s.

Acknowledgement

I wish to thank Professor S. H. Ayliffe for permission to publish this article and for the use of the facilities of his department.

REFERENCES

1. “Transistor FM Tuner” : P. J. Baxandall (Correspondence) *Wireless World*, September 1964, p. 460.
2. “Elements of Transistor Pulse Circuits” : T. D. Towers, *Wireless World*, August 1964, p. 403.

Books Received

Topology and Matrices in the Solution of Networks, by F. E. Rogers. An initial detailed explanation of the rudiments of topology is used as a basis for introduction to the matrix concept. The combined principles are extended progressively to the solution of network equations and then applied to fundamental theorems and four-terminal networks. Worked examples, given at the end of each chapter, link theory with practical application. Pp. 204; Figs. 100. Price 45s. Iliffe Books Ltd., Dorset House, Stamford Street, London, S.E.1.

Dynamic Circuit Theory, by H. K. Messerle. Written as an introductory course on electromechanical energy conversion and electromechanical systems, the book uses dynamic circuit theory as a basis for the formulation of the principles of electrodynamics. Particular attention is given to the derivation and analysis of lumped parameters and their use for representation of electromechanical devices. Double storage transducers, commutator machines, two- and three-phase machines, and multiphase systems are dealt with in detail. Worked examples are included. Pp. 657; nearly 330 Figs. Price £5. Pergamon Press Ltd., 4 & 5 Fitzroy Square, London, W.1.

The Invention of the Traveling-wave Tube, by Rudolf Kompfner. An interesting, lucid account of the research by the author which led to the invention of the travelling-wave tube. Parts of the text which recount particularly difficult stages of the work are tempered with humour and will act as a stimulant to others engaged in the arduous field of research. Pp. 30; Figs. 18. Price 10s 8d. W. Heffer & Sons Ltd., 3-4 Petty Curry, Cambridge.

Handbook of Electron Tube and Vacuum Techniques, by F. Rosebury. A new version of the Tube Laboratory Manual produced by the Research Laboratory of Electronics at the Massachusetts Institute of Technology. The introductory sections deal with procedures and techniques in the manufacture of thermionic valves and other evacuated devices.

The rest of the book contains a glossary of terms comprising a detailed and comprehensive compilation of definitions, materials, processes, etc., presented in graphical and tabulated form together with explanatory diagrams. Pp. 597; Figs. 154. Price £6 12s. Addison-Wesley Publishing Company, Inc., 10-15 Chitty Street, London, W.1.

The Electron in Electronics—Modern Scientific Concepts for Electronic Engineers, by M. G. Scroggie. Couched in the inimitable style for which the author is so well known, the book fulfils the need of students and engineers requiring a lucid explanation of the physics of the electron in modern electronics. Energy levels, work functions and valency bonds are dealt with in the introductory chapters which lead to the quantum theory and photons. The controversy of electromagnetic radiation—wave theory versus photon theory—is discussed in detail and includes the effects of polarization, diffraction and interference. Continued expansion of the text then covers semiconductors and aspects of atomic theory such as magnetogyric ratio, electron spin, nuclear spin and magnetic resonance. The final chapter is devoted to relativity. Throughout the text, the standard of mathematics and general physics does not exceed G.C.E. “A” level. Pp. 276; Figs. 132. Price 45s. Iliffe Books Ltd., Dorset House, Stamford Street, London, S.E.1.

Principles of Transistor Circuits (Third Edition), by S. W. Amos. First published in 1959, the contents have been expanded in successive editions to deal with later developments of the transistor. In this edition the general arrangement of the subject matter of the book remains the same—the physics of semi-conductors, design of transistors, receivers, oscillators and generators. Additions to the text include d.c. stabilization of amplifiers by direct coupled feedback, phase shift and Wien-bridge oscillators, blocking oscillators and transistor sawtooth generators. Two appendices give details of the manufacture of transistors and an explanation of transistor parameters. Pp. 293; Figs. 172. Price 35s (stiff cover), 25s (limp cover). Iliffe Books Ltd.

A Way of Speeding Up the Application of New Techniques to Medical Practice

Medical Instrumentation

By VLADIMIR K. ZWORYKIN^{*}, Ph.D., D.Sc.

As an introduction to the two forthcoming conferences on medical electronics, in Tokyo (29th August) and Brighton (28th September), Dr. V. K. Zworykin, who is an international leader in this field, gives his views on a problem which concerns him greatly—the excessive delay that occurs between the introduction of new instrumentation techniques and their application to medical practice.

Recently Dr. Zworykin, who is 76, was awarded the I.E.E.'s Faraday Medal for his notable scientific and industrial achievements, including the invention of the iconoscope, and his work in medical electronics.

FOR many years I have advocated the establishment of a chain of specialized institutions devoted to the advancement of medical instrumentation throughout the world, linked by our International Institute for Medical Electronics and Biological Engineering in Paris. While institutions of this nature have existed for a long time in several of the Eastern countries, in particular the U.S.S.R. and Czechoslovakia, I have found it relatively difficult, until recently, to develop the enthusiasm needed for their launching in the West and in the United States in particular. However, there are many signs that the climate is becoming more favourable for such ventures. Many influential voices have been added to my own, urging the creation of Institutes of Medical Electronics and Biological Engineering in various localities. This makes it desirable that we should examine what the structure and the functions of such an Institute might properly be. While my suggestions are necessarily tinged by my experience in the United States, the basic problems and conditions are sufficiently similar in other countries to make such an examination of general interest.

Our past experience with various national interdisciplinary professional societies, as well as with the International Federation of Medical Electronics and Biological Engineering, has emphasized the benefits to be derived from closer contact between the medical and engineering professions. The co-operation promoted by these groups has already proved exceedingly fruitful. At the same time it has thrown into clear relief a gap in the application of engineering knowledge to medical problems.

This gap exists primarily in the development of new devices for large-scale use in clinical practice. It may

be attributed to the long period of testing and evaluation which, in medicine, must intervene between the construction of an engineering model and the large-scale distribution of the final device. The resulting expense and delay in marketing, which finds no counterpart in other branches of industry, discourages private enterprise from ventures in the development of medical instrumentation. A primary objective of the Institute should be, I submit, to remove this impediment. In this manner the flow of promising ideas in the field of medical electronics and biological engineering, greatly augmented in the past years through interdisciplinary co-operation, would be directed most effectively to the advancement of medical practice and, with it, to the improvement of general health and well-being. The orientation of the Institute would thus be primarily practical, since the practical application of engineering methods in medicine has, so far, tended to lag far behind their application in scientific research in the life sciences.

It should be recognized that, in principle, any new group could undertake the launching of an Institute of the type here considered. However, it is vital for its success that it should benefit from close association, from the very beginning, with organizations in the field of medical electronics and biological engineering which have been built up in the past decade. This imposes, in my opinion, a special responsibility for this undertaking on those of us who have been intimately associated with the development of the above organizations.

With this preface, what might the structure and functions of the Institute be?

Let us first consider the structure of the Institute, which would be a non-profit organization. The control of the Institute would rest in the hands of a board of directors, consisting of persons deeply convinced of the importance of the mission of the Institute and ready to maintain a financially sound basis for its operations. It would be supported by a group of eminent technical advisers drawn from the engineering and medical professions. The board would appoint a Director of the Institute who, with his secretarial assistants, would constitute the initial permanent staff of the Institute. The Director, in addition to his other duties, would be charged with establishing rosters of specialists in the medical and engineering fields who could be drawn upon to carry through technical projects in their area of competence which have been undertaken by the Institute. These specialists might be persons retired from industrial and other organizations with a prescribed retirement age who are eager to contribute their skills to the humanitarian purposes served by the Institute. While placement on the roster would not imply remuneration of any kind, travelling and *per diem* expenses incurred in the service of the Institute would be reimbursed. The establishment of the rosters may be regarded as a device for circumventing the large initial expenditure inherent in setting up a well-rounded paid professional staff and, at

^{*}Vice-President and Technical Consultant, Radio Corporation of America.

the same time, utilizing an important available source of talent.

The activities of the Institute might include:—

1. Keeping informed concerning problems and ideas encountered in international medical practice and research and submitting them to members of the roster for evaluation with respect to importance and feasibility of further development.

2. Arranging for follow-up activity if the evaluation recommends further work; this could be carried on within the Institute or with the aid of outside organizations, always with the collaboration of the originator of the problem and of members of the evaluating panel.

3. Carrying on such evaluation and follow-up activities for other organizations under contract.

4. Application for grants for the construction of working models and further development by an appropriate organization if this appears justified.

5. Organization of working groups from the Institute roster to supervise work carried forward under such grants and to arrange for the publication of the results in the technical journals.

6. Making arrangements for patent protection and negotiating licensing agreements under patent rights acquired by the Institute, if, under the conditions prevailing in the country, this were consistent with obtaining support from other sources.

7. Seeking financial support for the Institute from industry, foundations, and other sources, making use of professional assistance as needed.

We can envisage the function and growth of the Institute taking the following course. To begin with, the staff would make known, through appropriate professional channels, that it was available for consultation on medical engineering problems encountering obstacles of a technical, financial or some other nature. The consultation might result in a referral to a commercial or scientific organization with interests in the same field or experience in solving problems of a similar nature, or it might point out published work with a bearing on the subject. Just by serving as a focus at which medical and engineering scientists would be together, the Institute would frequently provide the starting point for collaborative investigations. If a specific project required financing, the staff might put the applicant in touch with possible sources of support after a favourable evaluation of the project by members of the advisory panel.

The Institute would not concern itself with basic research investigations which are already well supported by other agencies, but would deal primarily with the design and application of medical instrumentation. In due time, as engineering designs perfected and tested with the assistance of the Institute became widely accepted in hospitals, the demand for them would increase to a level sufficient to yield a financial return to the electronic and mechanical industries which had made the original collaborative effort. As the Institute became more widely known and a greater range of problems was presented to it, the need for laboratory facilities would become evident. Thus, in response to demand, it might gradually develop into a larger-scale research institute of medical electronics and biological engineering. The necessary "*in vivo*" experiments, which initially would be carried out in co-operating hospitals and other institutions, might then be transferred to its own facilities. Thus the Institute might grow, from relatively modest beginnings, into an establishment fully equivalent to the extensive institutes for medical instrumentation set up in Russia and other countries of Eastern Europe.

I estimate that an Institute of the type here contem-

plated might be launched, under the conditions prevailing in the United States, with an initial annual budget of \$100,000 or less. This would just suffice to pay the Director and his assistants and provide the minimal office space and equipment required. Its growth would be determined by its recognized usefulness to industry and the medical and engineering professions. The favourable response I have received so far assures me that the growth of the Institute would be rapid and that it would come to provide an important service to the patient, the physician, and the research scientist alike.

We should lose no time in calling such Institutes into being. They would do much to close the gap between theoretical understanding and practical utilization in the application of engineering knowledge to medicine.

Chartered Engineers

THE granting of a Royal Charter to the Council of Engineering Institutions, formerly known as the Engineering Institutions Joint Council, has brought a step nearer the day when the titled "chartered engineer" (C.Eng.), without reference to a particular discipline, will be used by members of the 13 constituent institutions.* To this end it is proposed to introduce a common Part I examination which will benefit "cross-fertilization" between the different disciplines. It will not be easy to reconcile the varying requirements of the different institutions, each representing a specialized branch of science and technology.

In the Rules of the C.E.I. it is specified that there shall be "an examination in the principles of engineering which shall be set by the Council . . . and shall be of a standard at least equivalent to that of a degree in engineering currently awarded by a university. The Council will accept certain qualifications as exemption from this examination.

The Institution of Electronic & Radio Engineers has issued a policy statement regarding the proposed common examination. "It has been clear," it says, "from the outset that this will preclude the degree of specialization which characterizes engineering studies today, particularly in the universities, where departments, chairs, and new courses in electronics have slowly but steadily appeared since the war."

It is pointed out that through the proposed regulations governing the examination the C.E.I. "will exert a powerful influence on the structure and content of courses of study in colleges of technology and even the universities. Proposals which are in sharp contrast with accepted practice in engineering education deserve for that very reason, more thorough and prolonged discussion."

The I.E.R.E. warns against the possibility of the Council foundering "on the uncharted rocks of educational policy, many of which are not yet discernible," and adds "A liberal conception of the specialist requirements of the individual engineering professions is most necessary if we are to avoid the mistakes of the past in restricting development of new technologies."

The proposed Pt. I syllabus comprises papers in the following subjects:—mathematics, properties of materials, principles of electrical engineering, applied mathematics, fluid mechanics and thermodynamics.

While giving support to the principle of a common examination the I.E.R.E. feels that it cannot agree that this demands a Part I exam with no optional papers. It therefore proposes an examination based on a core of four compulsory papers of a broader basic coverage (such as mathematics, engineering science, principles of both mechanical and electrical engineering) plus at least one optional paper to cater for the requirements of individual institutions.

*Royal Aeronautical Society; Institution of Chemical Engineers; Institution of Civil Engineers; Institution of Electrical Engineers; Institution of Electronic and Radio Engineers; Institution of Gas Engineers; Institute of Marine Engineers; Institution of Mechanical Engineers; Institution of Mining Engineers; Institution of Mining and Metallurgy; Institution of Municipal Engineers; Institution of Production Engineers; and Institution of Structural Engineers.

EPITAXIAL GUNN-EFFECT DEVICE

AN epitaxial version of the Gunn-effect device has been developed as an experimental microwave oscillator by Standard Telecommunication Laboratories (see "The Gunn-Effect," *Wireless World*, August 1965, p. 416). It has a volume of 0.1 in³ and is said to produce several milliwatts of power at 1 Gc/s. S.T.L. explain that the epitaxial construction enables the frequency and the threshold power

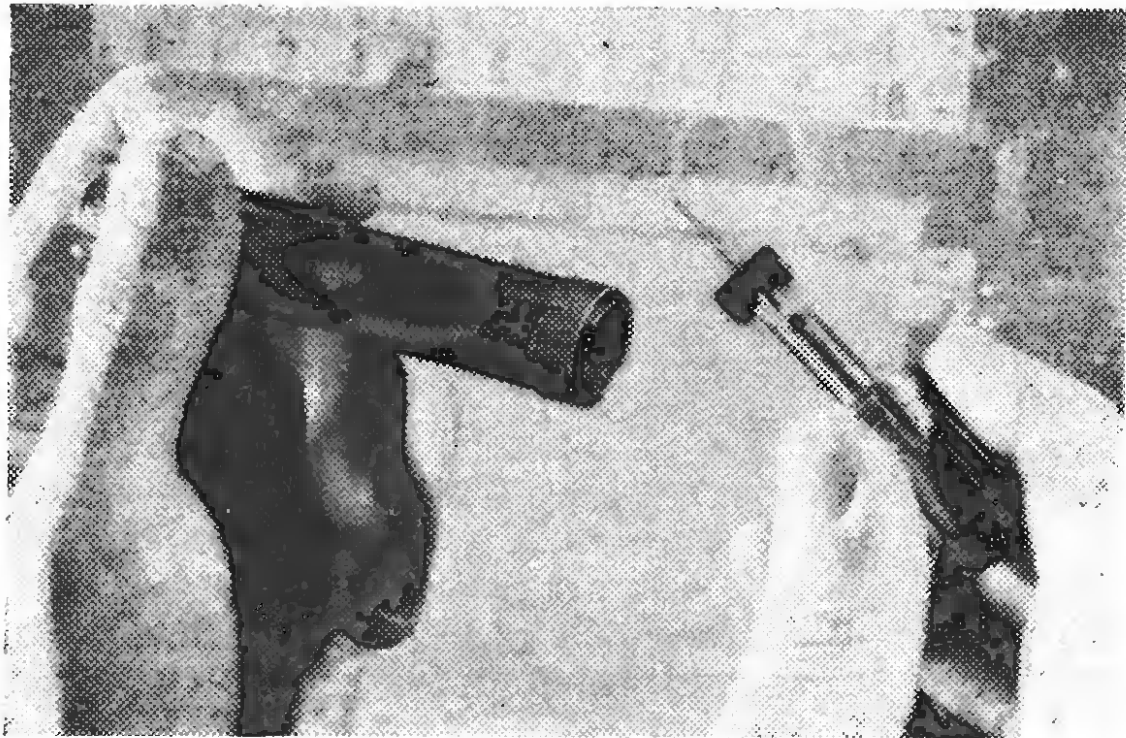

of the device to be determined independently of the resistivity of the active region or the mechanical and thermal properties.

On a substrate of semi-insulating gallium arsenide about 100 μ m thick is grown a 15 μ m layer of gallium arsenide whose properties are optimum for the active region of the device. The effective cross-sectional area for the current path is determined by removing part of this layer to form a narrow track 100 μ m wide. The anode and cathode are formed by converting two parts of the track to n+ regions,

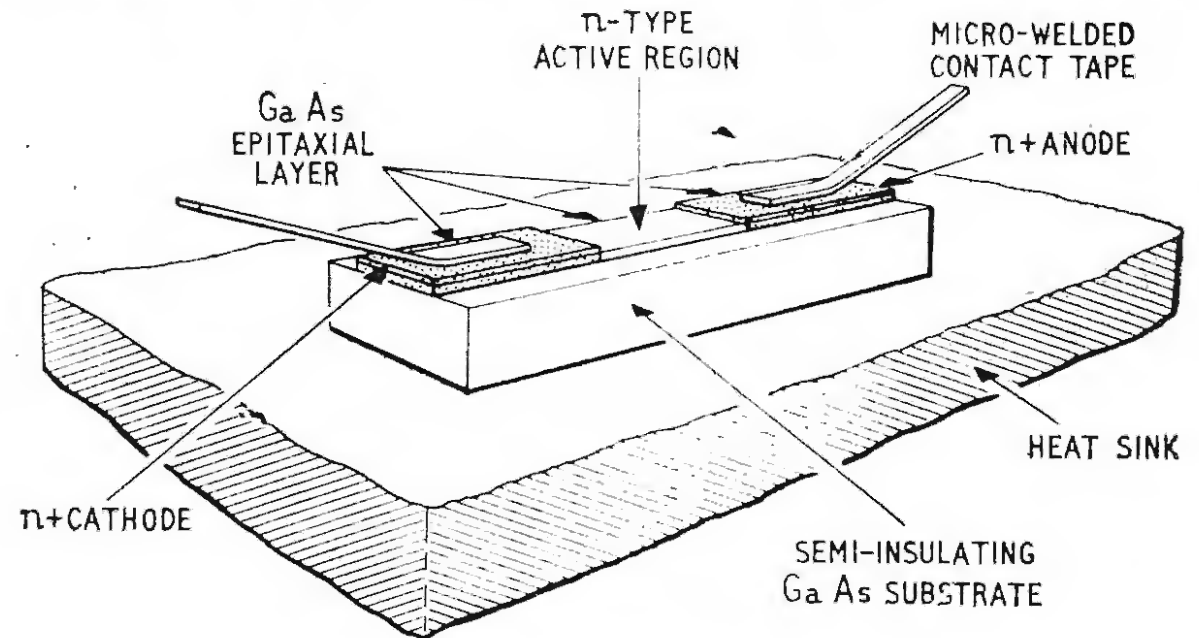

leaving a gap of the original n-type material between them, the length of which determines the self-oscillating frequency. The semi-insulating substrate is bonded to a heat sink and electrical connections to the anode and cathode are made by micro-welding tapes to metal contacts on the top surface of the n+ regions.

The shape of the substrate controls the mechanical and thermal properties of the device. The electrical properties, determined by the dimensions of the epitaxial n-type track, can be varied independently of the shape of the substrate. It is stated that the configuration is suitable for mass production, using precision masking techniques similar to those employed in the manufacture of semiconductor integrated circuits.

S.T.L. are also looking into the idea of three-terminal Gunn-effect devices in which domain formation can be influenced by the potential of an isolated gate electrode similar to that in a metal oxide semiconductor transistor—the cathode and anode being in the positions of the source and drain of the M.O.S.T. respectively.

625-LINE TELEVISION WAVEFORM

LATEST change to the B.B.C.'s 625-line vision signal waveform is the addition of a test signal for use in automatic test equipment at unattended transmitting stations. This signal is inserted on lines 17 and 330, and consists of a 12.5 μ s bar, a sine-squared pulse (half-amplitude duration 0.2 μ s) and a five-step staircase. The first four steps of the

staircase have a duration of 5.3 μ s and the final step a duration of approximately 4.0 μ s, all steps being of equal height.

The B.B.C. has also published tolerances on the figures in the 625-line vision and sound signal specification, and for the benefit of readers who may not possess up-to-date information we give here the current specification together with the idealized carrier amplitude waveform.

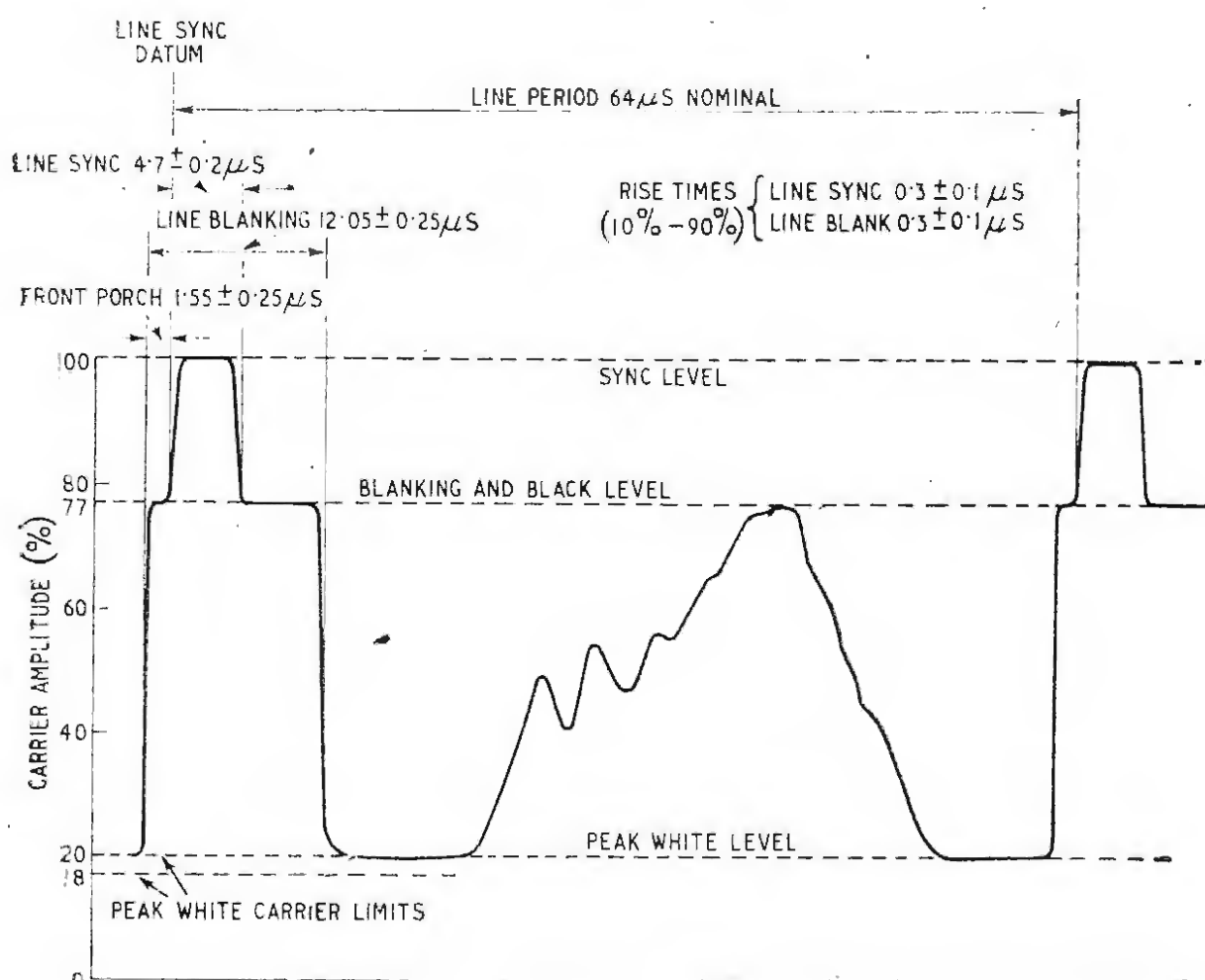

Channel bandwidth	8 Mc/s
Spacing between unmodulated sound and vision carriers ..	6 Mc/s \pm 1,000 c/s
Vision modulation	a.m. negative
Upper sideband	5.5 Mc/s
Lower sideband	1.25 Mc/s
Synchronizing level	100%
Blanking level	76% \pm 1%
Difference between black level and blanking level ..	0%
Peak white level	19% \pm 1%
Sound modulation	f.m.
Peak deviation	50 kc/s
Pre-emphasis	50 μ s
Ratio of peak vision carrier power to sound power ..	5 : 1
Lines per picture	625
Interlace	2 : 1
Field frequency	50 c/s
Line frequency	15,625 \pm 0.15 c/s
Approximate gamma of picture signal	0.5
Nominal video bandwidth	5.5 Mc/s
Aspect ratio	4 : 3

Transmissions are normally asynchronous, i.e. the sync signals are derived from a stable oscillator and are not locked to the mains.

Electronics for "Mediator"

Comprehensive air traffic control scheme designed to cope with the rapidly increasing density and speed of air traffic over the United Kingdom

EXTENDED radar coverage and automatic data processing are the two electronic cornerstones of a comprehensive air traffic control scheme now gradually being introduced in the U.K. under the code name "Mediator". The radar surveillance will eventually cover the whole of the U.K. Flight Information Region below 57°N, from a height of 5,000 ft upwards. It is being provided initially by primary radar stations, but these will gradually be supplemented by co-located secondary radars which will assist in identifying aircraft and provide accurate information on their heights. The automatic data processing equipment, based on electronic digital computers, will not only reduce the controllers' normal work-load by maintaining an up-to-date store of information on the intention and progress of all aircraft, performing automatically all the necessary analysis and correlation of different information sources, but will also make possible the rapid prediction of conflicting flight paths.

Government N.A.T.C.S.

The new scheme is being put into operation by the National Air Traffic Control Services. This is a Government body which was formed in 1962 for the express purpose of setting up a comprehensive a.t.c. system and which is responsible to both the Ministry of Aviation (for civil aircraft control) and the Ministry of Defence (for military aircraft control). "Mediator" is comprehensive because it will serve all users of British airspace—airlines, charter companies, military aviation, research and development flying, private business users

and so on, right down to gliding clubs. The impetus for the scheme has come from the rapidly increasing density and speed of air traffic. From 1957 to 1964, for example, civil air transport movements in the U.K. airspace increased by nearly 50%, while the top speed of civil aircraft rose during this period from about 300 knots to about 600 knots. This has demanded a corresponding increase in the information handling capacity of the air traffic control loop (information gathering—decision making—transmission of instructions), an increase which could not be provided by the existing facilities nor by a straightforward multiplication of the existing equipment and personnel.

Hitherto air traffic control has been based on the so-called "procedural" method (in which pilots report their positions to controllers by R/T), while radar has served mainly in a monitoring or backing-up role. With the increasing density and speed of air traffic, the information gathering part of procedural control is now beginning to show limitations (e.g., errors can occur in reading aircraft instruments and in air/ground voice communication). These limitations restrict the volume of air traffic that can be handled because the standards of separation between aircraft have to be sufficiently large to allow for the errors in time and space that can occur. This is a particularly serious problem in and around the London Terminal Area. Radar, however, which requires no co-operation from the pilot, is inherently faster and more accurate as a means of position finding, and is consequently beginning to assume a more important role in control operations—especially now that secondary radar is being adopted more widely. Be-

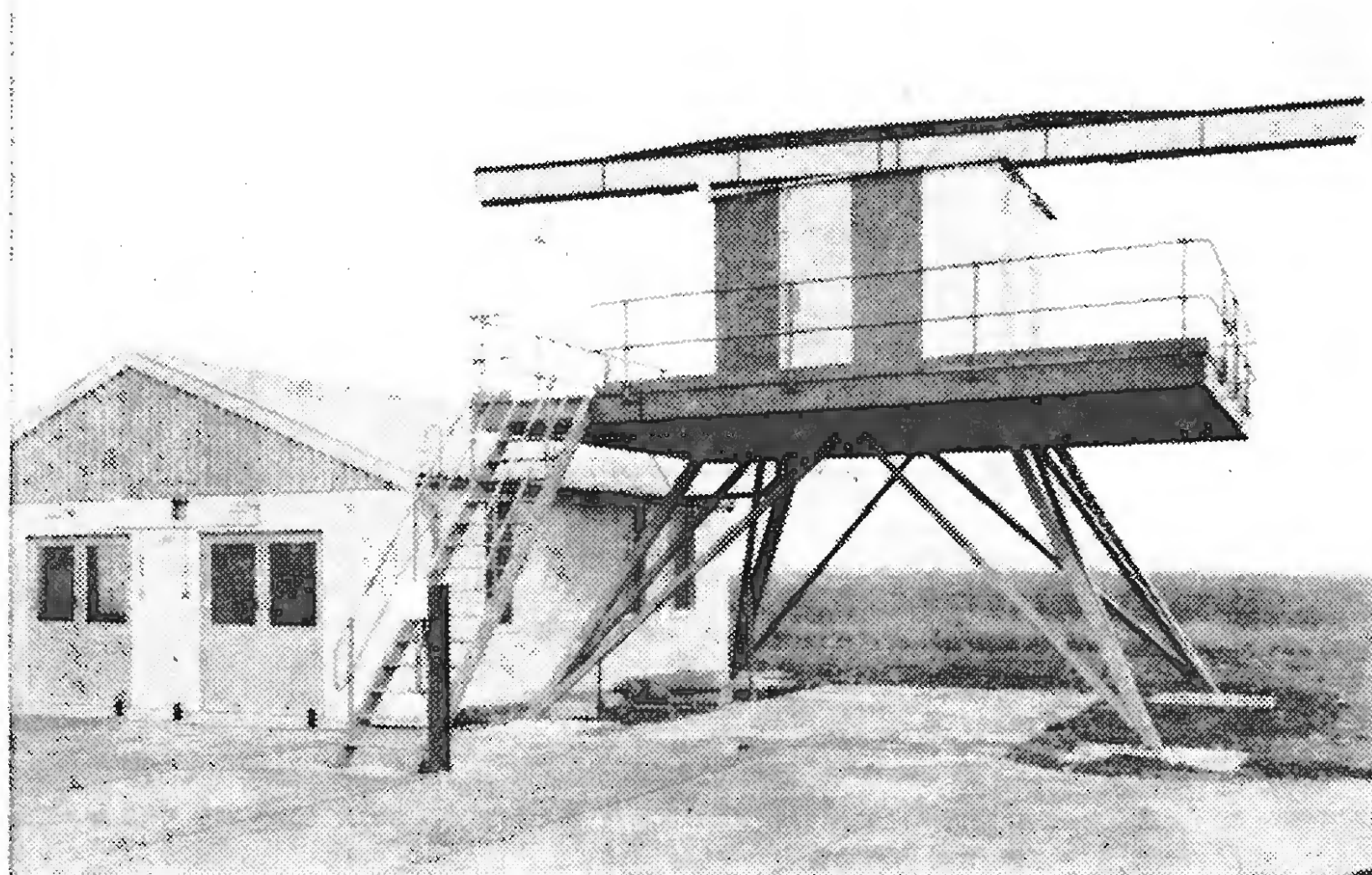

Cossor SSR.5G secondary surveillance radar installation at London Airport. Interrogator/responders and servo equipment are housed in the building.

cause of this, aircraft separation standards for radar control are smaller than for procedural control. These, then, are the basic reasons why the existing a.t.c. radar coverage is being extended in the new scheme.

There are similar reasons for the introduction of

automatic data processing in place of conventional a.t.c. methods of handling information. Here the main problem is to process the increasing volume of information at sufficiently high speed to allow effective control. Each controller can cope with only a limited number of air-

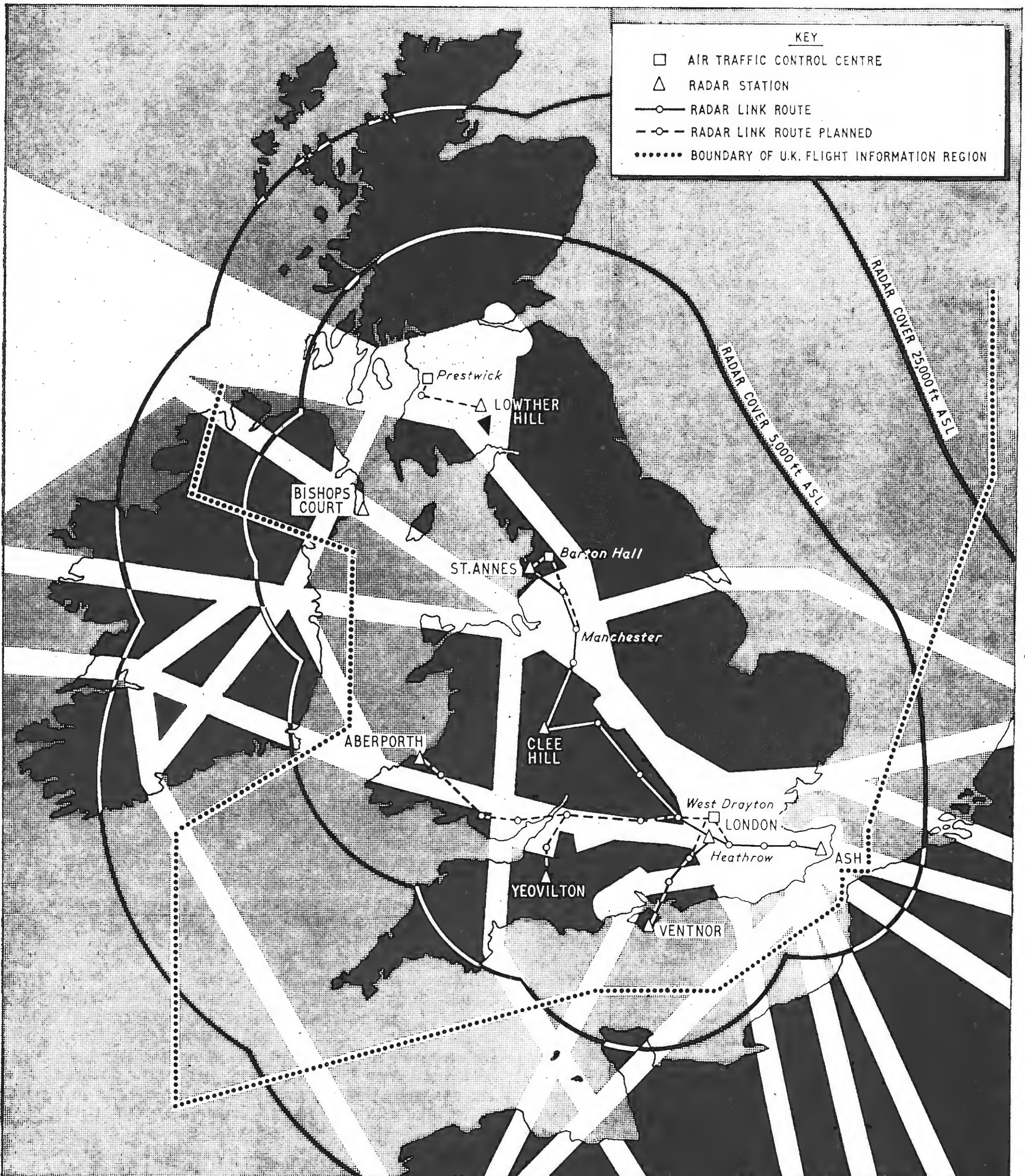

Fig. 1. Radar network to be completed by 1969, showing main airways and other controlled airspace, new air traffic control centres, and radar coverage at 5,000 ft and 25,000 ft. The boundary of the U.K. Flight Information Region is indicated.

craft. Under the present method of working an increase in air traffic calls for an increase in the number of controllers—but this means that more time must be spent in communicating between controllers. Furthermore, the increase in traffic density results in control problems of greater complexity, which take correspondingly longer to solve by human mental processes. The use of automatic data processing equipment will enable these delays to be reduced considerably, so that they no longer present a serious time lag in the control of high speed aircraft; it will also facilitate predictive operations such as calculating times of arrivals and possible conflicts between flight paths.

In the new scheme the airspace of the U.K. Flight Information Region, Fig. 1, will be divided up horizontally by the existing airways (which are defined by radio navigational aids and mainly used by airlines) and vertically into the following sections: upper airspace (above 25,000 ft), middle airspace (above 5,000 ft and below 25,000 ft), controlled airspace (the airways part of the middle airspace in which positive control is exercised) and lower airspace (below 5,000 ft). The degree of control exercised will vary throughout this total airspace in a complex pattern determined by the forecasted increase of aircraft movements in the horizontal and vertical divisions, and will range from a minimum of control in the upper airspace in the north of Scotland to maximum control in the controlled airspace above the London Flight Information Region. Two types of information will be required from all aircraft moving through this total airspace. The first is flight plan data—a statement of intention which must be filed by every aircraft entering the system and which is subsequently fed into the data processing equipment by keyboards. The second is flight progress data—mainly the output of the primary and secondary radars, giving aircraft identification, position and height—which is fed directly into the data processing system (in the later stages of the project without human intervention).

Progressive introduction of the scheme

How far has the new scheme progressed? The radar network is the most advanced part. New primary radars at London and Manchester serve the controlled airspace, and the cover they now provide will be greatly extended by the progressive introduction into service of new radars at Ash (Kent), St. Annes (Lancs), Clee Hill (Shropshire), Ventnor (I.o.W.) and Lowther Hill (Lanarks) and by the addition of existing radars at Yeovilton (Somerset) and Aberporth (Cardigan). Ash and St. Annes should be operational this September, Clee Hill and Ventnor before the end of this year and Lowther Hill in 1967, and Yeovilton and Aberporth will be added to the system in 1968. All radar stations have been, or are being, linked to the air traffic control centres they serve by wide-band microwave links. Secondary surveillance radar (s.s.r.) is being progressively added to all the radar stations—the installation at London is complete and others are in progress at Ash and Ventnor.

All primary radars mentioned are Marconi S264A equipments, with the exception of Aberporth (Marconi S300) and Clee Hill (Plessey DASR-1). London, Ash and Ventnor s.s.rs. are Cossor SSR5G equipments. Radio link equipment connecting St. Annes, Ash, Ventnor and Clee Hill to their air traffic control centres is of Marconi manufacture.

For the upper airspace, new equipment is being installed at joint civil/military a.t.c. radar units at Bishops

Court (N. Ireland), Sopley (Hants), Boulmer (Northumberland) and Hack Green (Cheshire), while two new military radar units at Lindholme (Yorks) and Watton (Norfolk) will be fully operational by July 1966. The middle airspace will be served by the units at Lindholme and Watton, and also by a new unit at North Luffenham (Rutland), which will provide general radar surveillance in the Vale of York, East Anglia and the Midlands. Information from the London, Ash and Ventnor radars will also be used to give an improved radar control service to aircraft flying in the London Flight Information Region, crossing the airways and in the London Terminal Area.

Data processing and display

As for the information processing and display operations, these will be divided between three air traffic control centres: a Scottish centre at Prestwick airport, a Northern centre at Barton Hall (Preston) and a Southern centre at West Drayton, near London (Heathrow) Airport. The Scottish centre, controlling all airspace north of 57° N and the middle airspace north of the Clyde-Forth valley, will use raw radar information and no automatic data processing. The Northern joint centre, dealing with the middle and controlled airspace in the north-west area, will not have automatic data processing equipment installed but will be able to make use of information processed at West Drayton. The Southern centre, which will be responsible for all the rest of the controlled and middle airspace and for all the upper airspace south of 57° N, will be the largest of all three centres and will house the automatic data processing equipment for the whole scheme. The building at West Drayton has been completed, the procedural control element of the existing S.A.T.C.C. at Heathrow is being transferred into it and the first stage of electronic information handling is expected to be working in 1966.

Fig. 2 shows in broad outline the equipment to be installed at the West Drayton S.A.T.C.C. Positional information from remote primary and secondary radar stations is received via 7-Gc/s broad-band radio links and from the local radars at London (Heathrow) Airport via G.P.O. coaxial cables. Signals available at the radio link terminal are primary and secondary video, trigger pulses and aerial turning information. These signals are distributed to various destinations—to raw radar displays on controllers' consoles in the operations room, to extraction equipment and to secondary radar decoding equipment. In the extraction equipment the analogue positional information is converted into digital form, and is then fed into the radar data processing equipment where it is converted into Cartesian coordinates and stored.

The function of the radar data processing equipment is to maintain track records of all aircraft (these being continuously up-dated by fresh positional information), to detect possible track conflicts (by prediction of future radar responses) and to read out this track information for marking of raw radar and synthetic radar displays. The secondary radar decoding equipment provides aircraft identity and position information for the extraction equipment and also gives identity and height read-outs at controllers' consoles and s.s.r. marking of raw radar displays.

In procedural control the principal document for recording aircraft information—identification, destination, estimated time of arrival, etc.—is the flight progress strip. Information needed by controllers is taken

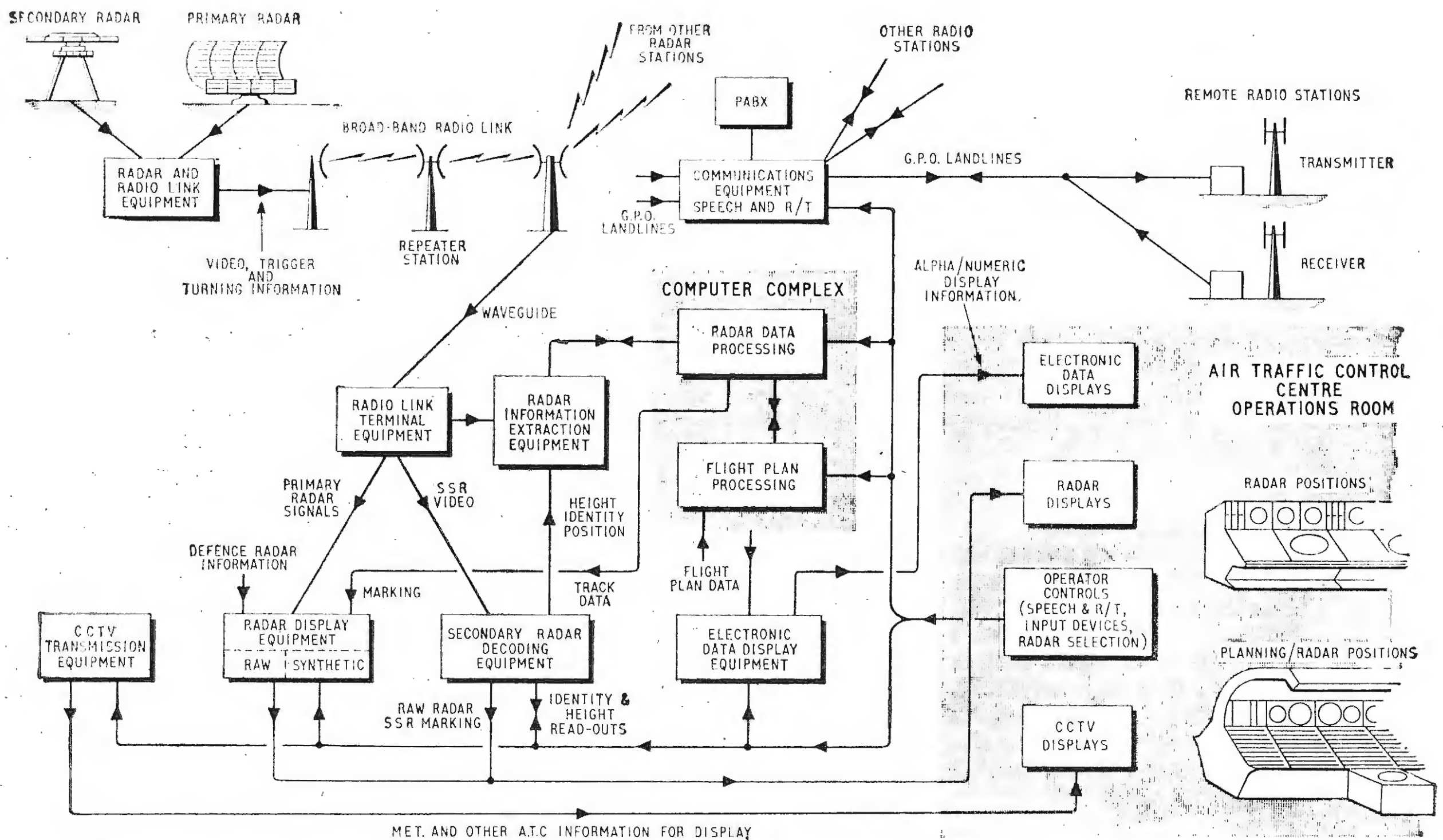

Fig. 2. Outline of information processing and display equipment at the new West Drayton air traffic control centre, showing remote radar and radio stations and the local operations room.

from the pilots' flight plans and is normally written by hand on these progress strips. As a first step in the evolutionary development of an automatized a.t.c. system, a Ferranti Hermes computer and associated peripheral equipment (not shown on Fig. 2) will be used to print the strips automatically. Flight plan data will be fed into the computer, and the flight progress strips printed, by IBM input/output writers. Two of the IBM printers will be at Heathrow, where the strips will be used in ground movement planning and at the "air control" positions.

Continuously up-dated information

The next stage will be the introduction of a flight plan processing system, and this is indicated in Fig. 2 by the second block of data processing equipment within the computer complex. This equipment receives manually inserted data on the planned movements of aircraft and, after checking them for acceptability, performs flight path calculations (using also the processed radar data) and finally provides output selections of the inserted and calculated data. These selections are made by the controllers in the operations room, by operating switches which send demands for the required information to the computer complex. Data called up in this way are displayed to the controllers in alpha-numeric tabular form on c.r.t. displays, the data format being determined by the computer system.

Communication with aircraft is effected in the normal way through the existing v.h.f. multi-carrier radio network, the speech signals between West Drayton and the remote transmitters and receivers being conveyed by G.P.O. landlines. At each remote radio station the transmitting and receiving installations are separated

by a mile or more to avoid inter-action between signals on closely spaced frequencies and the consequent generation of spurious signals.

Two types of controller are catered for in the design of the operations room consoles—the procedural controller, who will act mainly in a planning capacity, and the radar controller, who will be more of an executive controller. One type of console will be purely for radar control functions in the middle air space, while the other will allow planning and radar control functions to be carried out together for the controlled airspace. The design of the consoles has not yet been fully settled but the radar (m.a.s.) console is a double unit, for an a.t.c. officer and an assistant, and incorporates either one or two radar viewing units, up to three alpha-numeric data displays, a closed circuit television display, controls for the flight plan data processing system and channel-selection units for the air/ground radio communications system.

Thus, in the operations room the air traffic controllers will have presented to them, on a variety of displays, continuously up-dated information on aircraft identification, intention, actual and predicted position and height, flight path conflicts and flight plan deviations. The computer complex will be able to allocate tasks to controllers on a sector or workload basis, indicate the priorities of these tasks, detect and give warning of actual and planning flight path conflicts, provide rapid automatic routing of communications between controllers, and transfer control as necessary. As a result the controllers will be able to make decisions on the basis of a common fund of information which will be as complete and up-to-date as is possible to achieve with electronic engineering techniques and equipment which are both modern and reliable.

SWITCHED THYRISTOR VOLTAGE REGULATOR

By F. BUTLER, O.B.E., B.Sc., M.I.E.E., M.I.E.R.E.

THE most efficient way of producing a constant load-voltage from an unregulated d.c. source is to use a switched thyristor as a control element between source and load. When it is conducting, the voltage drop across it is between 1 and 1.5 V, and with a load current up to 10 A the loss will not exceed 15 W. When blocked (non-conducting), the energy loss in the thyristor is zero.

Two switching modes are possible. In one, the average switching rate is held constant but the proportion of the total time during which the switch remains closed is variable. The method is commonly described as time-ratio control and it may be exercised manually or automatically. A second method of control is to switch on the thyristor and then turn it off after a fixed period of time. In this case regulation is effected by varying the repetition frequency of the fixed-duration pulses. The second method is rather simpler to engineer and its only disadvantage is that on light load the pulse recurrence frequency may fall so low that filtering becomes difficult. In practice this effect is only troublesome in variable-voltage supplies which are required to operate at maximum load current with a very low output voltage setting.

Thyristor turn-off methods

A controlled rectifier can be turned on by a low-level short-duration positive pulse into the gate electrode. The problem is to turn it off. Six or seven methods of doing this have been proposed, most of them having some objectionable features, notably cost or complexity. All involve the same basic principle, which is to charge up a capacitor to a high voltage and then to discharge it through the thyristor in a direction opposite to that of the normal load current. The controlled rectifier will block if the load current is reduced to zero for about 60 microseconds or if a reverse voltage can be maintained across it for at least 20 microseconds.

One of the simplest and most reliable turn-off circuits was suggested by R. E. Morgan of the (American) G.E. Company. It is shown in Fig. 1. In the steady state,

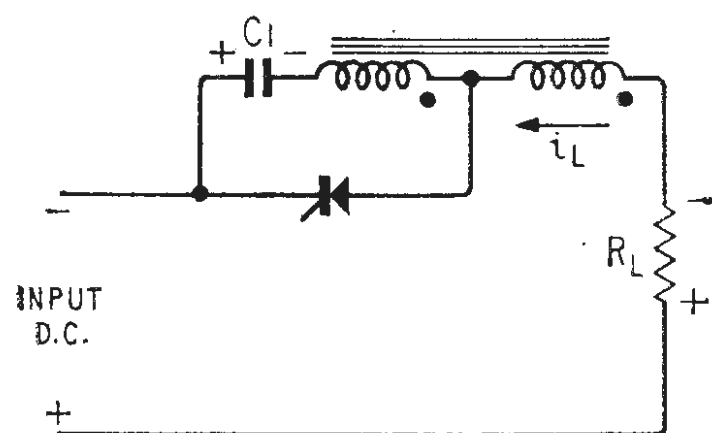

Fig. 1. Thyristor turn-off circuit due to R. E. Morgan.

before the thyristor is turned on, the capacitor C_1 becomes charged up to the input direct voltage, with a polarity opposite to that shown on the diagram. There is no flux in the auto-transformer core, no voltage across either of its windings and the load voltage is zero. On firing the controlled rectifier, a current shown as i_L , passes through one winding of the transformer and

through the load. The induced voltage in the other winding charges up the capacitor with the polarity shown, which is opposite in sense to the initial charge. At first the charging current into the capacitor is such as to produce an ampere-turn balance with the current in the primary or load section of the winding. The core remains unsaturated. When the capacitor becomes fully charged the current into it sinks to zero but load current continues to flow in the primary winding. In consequence the core material (nickel-iron or permalloy), becomes saturated and both winding impedances become very small. In effect the capacitor is then connected directly across the thyristor but with a polarity in the correct sense to turn it off.

The circuit has some good features. For example, an increase of load current will cause more complete magnetic saturation of the core of the transformer and also the capacitor becomes charged to a higher peak voltage.

Fig. 2. Modified version of the Morgan circuit.

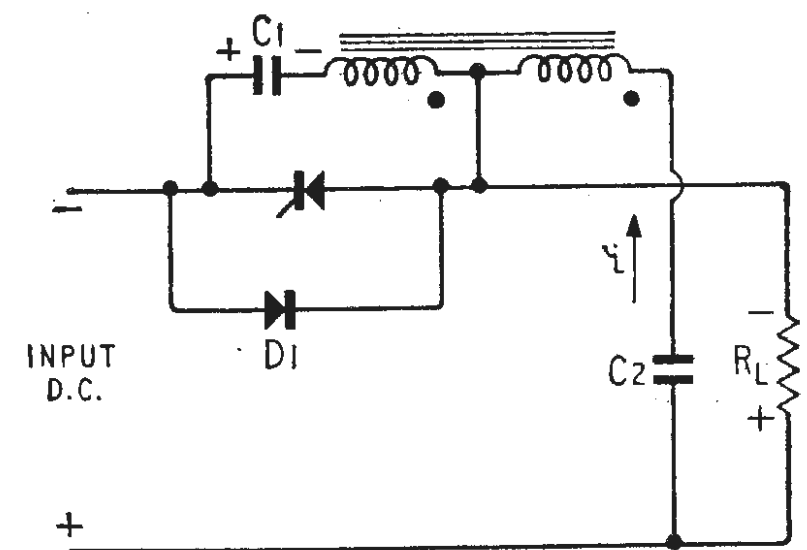

Both effects co-operate to give a more positive and abrupt turn-off of the thyristor. The turn-off mechanism is inoperative on no load and a dummy load must be used to cope with this condition. A second, more minor disadvantage is that the turn-off pulse characteristics tend to vary with the load current.

The writer has found that a modified version of Morgan's circuit can be made to give reliable turn-off under a wide range of load conditions, provided only that, as is also necessary with Fig. 1, the input voltage is considerably higher than the required maximum load voltage. It need hardly be remarked that this does not imply a reduced conversion efficiency in either circuit. The new arrangement is shown in Fig. 2. One feature is that the auto-transformer has been taken out of the main load circuit. When the thyristor is turned on by means of a positive gate pulse the forward voltage drop across it sinks to about 1 V and load current flows in R_L . At the same time a current pulse is passed by C_2 , which is initially uncharged. This current pulse in the primary winding of the transformer induces a high voltage in the other winding, charging up C_1 with the polarity shown. This is in the correct sense to turn off the thyristor as in the Morgan circuit. The diode D_1 is not strictly necessary but it serves two useful purposes. Provided that it is of the fast recovery type (low hole-storage time), it protects the thyristor from exposure to high peak inverse voltages. It also serves to discharge C_1 in the shortest possible time. Clearly the action of this turn-off circuit is independent of the magnitude of the

ments. The construction and mode of operation of the unijunction device have been described by the writer in an earlier paper.* Briefly, it forms a relaxation oscillator which produces a saw-tooth waveform across a capacitor which is periodically discharged to produce a short duration pulse for firing the thyristor. The repetition rate can be varied by changing the capacitor size or by varying the charging current.

In Fig. 3, the charging current is determined by an output voltage sensing arrangement of two transistors Tr1 and Tr2; the transistors (high gain low power p-n-p types) form a differential amplifier. The base of one of them is supplied with a constant reference voltage from a 5.6 V Zener diode. The base of the other is taken to the slider of a potentiometer connected across the output terminals of the power supply. A rise of output voltage increases the base current of Tr2 and causes a greater voltage drop across the common emitter resistance. This in turn reduces the collector current of Tr1 which constitutes the capacitor charging current. The reduced charging current lowers the recurrence frequency of the firing pulse train and restores the output to its original voltage.

At full load the p.r.f. is about 3 kc/s. Load current pulses of this frequency are easily filtered with moderate values of inductance and shunt capacitance. The remaining component, not so far discussed, is a 100-ohm 10 W resistor, permanently connected across the output terminals. It ensures positive turn-off of the thyristor under external no-load conditions.

Performance

The percentage voltage regulation depends mainly on the gain of the error-signal amplifier. With high gain transistors Tr1, Tr2 the regulation against load current changes is within 1 or 2 per cent from zero to full load.

* "Controlled Rectifiers in Stabilized Power Supplies," by F. Butler, *Wireless World*, October 1963, p. 480.

The precise figure depends on the output voltage setting. Against supply voltage changes the performance is even better. An input voltage change of 100 per cent has an almost imperceptible effect on the output voltage. The 20 V Zener diode which regulates the working voltage of the unijunction transistor contributes to this result.

The response time to step changes of load current is set mainly by the time constant of the main filter circuit. It cannot be less than the reciprocal of the low-pass cut-off frequency. In other words, the better the filtering the longer is the response time. Preferably, all the smoothing should be accomplished in a single stage and by using a high firing-pulse frequency this amount of filtering will be found satisfactory and the transient response is good enough for most applications.

Circuit losses are quite small. If p.n.p. silicon transistors are used for Tr1 and Tr2 the equipment will work well over the temperature range -20 to at least 80°C.

A fast-acting fuse in the input circuit will give acceptable protection against overloads though it would fail to safeguard a transistor regulator. Still better protection, almost instantaneous in action, can be given by shunting a transistor or silicon controlled switch across the charging capacitor of the unijunction oscillator and arranging for the voltage drop across a sensing resistor, under overload conditions, to bias the shunt element into conduction, thus inhibiting firing pulses.

The only real disadvantage of power supplies of this type springs from the very perfection of the thyristor as an electronic switch. It can be turned on and off in a matter of microseconds and these switching transients are quite difficult to suppress, reminding one of the difficulties at one time experienced with vibrator power supplies. The effect is most troublesome if the regulator is used to supply radio receivers, low-level digital circuits or high-gain broad band amplifiers. However the most useful applications of thyristor stabilized supplies are in the high voltage, high power field where efficiency and reliability are of much greater consequence than a noise-free output.

H. F. PREDICTIONS — SEPTEMBER

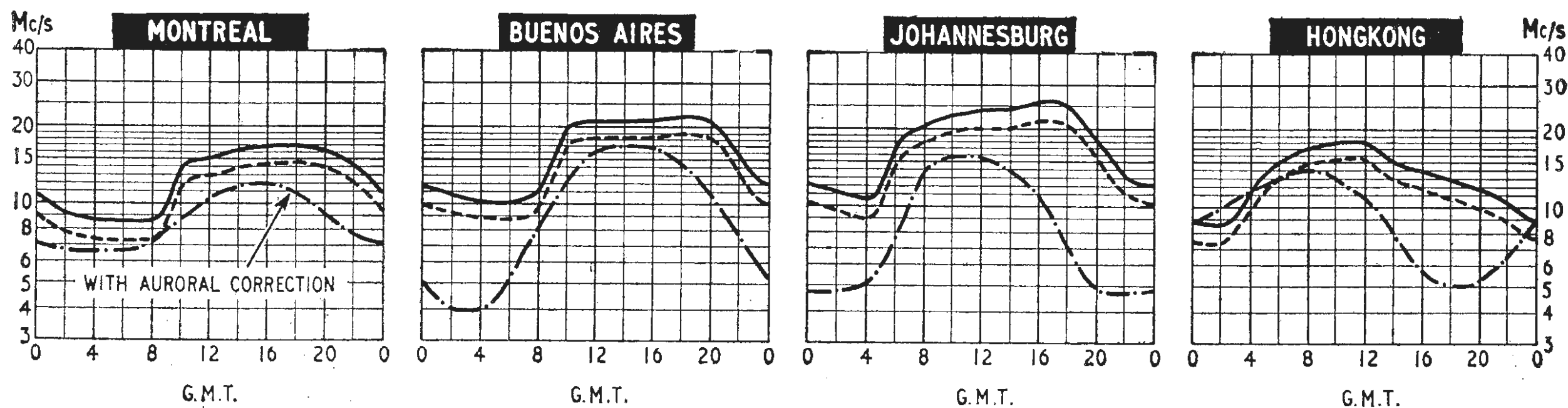

The MUFs are beginning to show the effect of the slowly rising Ionospheric Index. The predicted Index has risen from 12 in June to 22 for this month. Comparisons with the predictions for previous years show that the MUFs are about 1 Mc/s higher than in 1964 or 1963, and comparable with those of 1962.

The prediction curves show the median standard MUF, optimum traffic frequency and the lowest usable frequency (LUF) for reception in this country. Unlike the standard MUF, the LUF is closely dependent upon such factors as

transmitter power, aerials, and the type of modulation. The LUF curves shown are those drawn by Cable and Wireless Ltd. for commercial telegraphy and assume the use of transmitter power of several kilowatts and rhombic type aerials.

Subscription Television

THE Postmaster General, the Rt. Hon. Anthony Wedgwood Benn, has announced that the Government intends to continue with the subscription television experiment despite the withdrawal of all but one company from the pilot scheme.

Last year the P.M.G. announced the names of five organizations which were offered licences to enable them to participate in the experiment—the licence to be valid for three years from the date of commencement of service. Subsequently, licences were issued to three, Pay-TV Ltd., Choiceview Ltd. and Telemeter Programmes Ltd. Of these three only Pay-TV intends to continue and the areas in which it is licensed to operate are Sheffield and London (initially the Boroughs of Westminster and Southwark). Programmes are to be the responsibility of the operator and will be fed via relay networks to subscribers who will pay for viewing time by means of coin boxes fitted to their receivers.

The decision regarding the introduction of a permanent service will depend upon the analysis of results based upon economic and social factors involved. For example, one of the many factors to be considered is that of the effect on cinema attendances, and the Board of Trade is being consulted to arrange for protection of the legitimate interests of cinema exhibitors in the areas in which the pilot scheme will operate.

I.T.U. Plenipotentiary Conference

MORE than 500 delegates from most of the 127 member countries will be participating in the Plenipotentiary Conference of the International Telecommunication Union (I.T.U.) which opens in Montreux, Switzerland, on September 14th.

The Plenipotentiary Conference is the I.T.U.'s supreme authority although this year's conference, which takes place in the Union's centenary year, is only the ninth to be held. The founding conference met in Paris in May 1865 and succeeding conferences took place in Vienna in 1868, Rome 1871, St. Petersburg 1875, Madrid 1932, Atlantic City 1947, Buenos Aires 1952 and Geneva 1959.

The main purpose of the Plenipotentiary Conference is to revise the I.T.U. Convention—the Union's basic charter.

The U.K. delegation will be led by W. A. Wolverson, C.B., deputy director of the G.P.O.

Broadcast Receiving Licences.—During the first six months of this year the number of combined television and sound receiving licences in the U.K. increased by 203,321 bringing the total to 13,358,003. Sound-only licences fell by 92,959 to 2,766,874; this figure includes 638,642 for sets in cars representing an increase of 22,342. On August 1st, the combined television and sound licence fee was increased from £4 to £5 and the sound-only licence from £1 to £1 5s.

Confederation of British Industry.—The Federation of British Industries (F.B.I.), the National Association of British Manufacturers (N.A.B.M.) and the British Employers' Confederation (B.E.C.) have amalgamated to form the C.B.I. which was established by a supplementary Royal Charter effective on July 30th. The charter supersedes the original charter granted to the F.B.I. All communications should now be addressed to the Confederation of British Industry, 21 Tothill Street, London, S.W.1 (Tel.: WHitehall 6711).

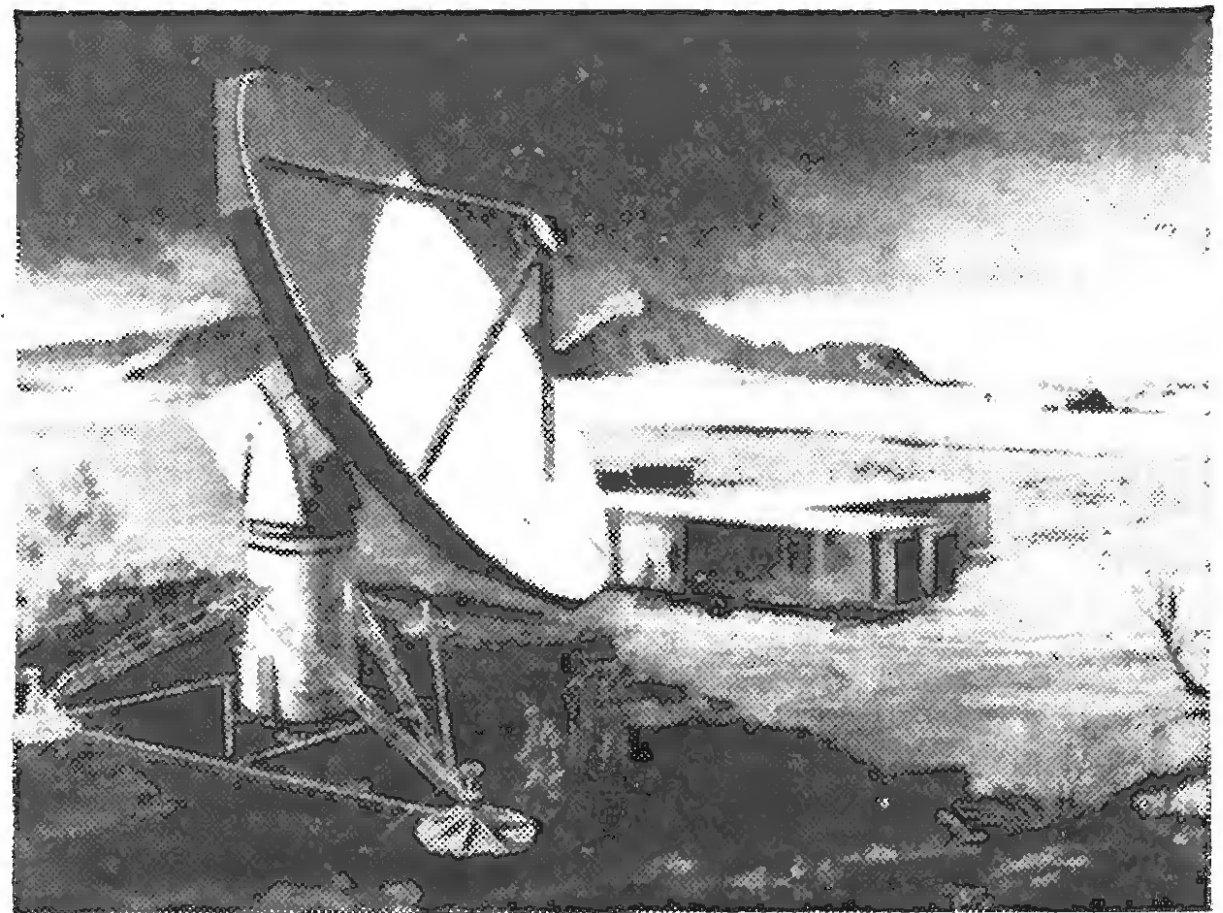

Mobile ground station links for satellite communications are being designed and built by the communications division of Hughes Aircraft Company to enable existing and future satellites to be linked in a worldwide communications network. Each mobile station consists of three power units, three equipment vans and a 40ft diameter paraboloid as shown in the illustration. Four voice and five teleprinter messages can be received, amplified and transmitted simultaneously via synchronous or medium altitude active satellites.

The first I.E.E./I.E.R.E. joint meetings of the 1965/6 session will be held on September 29th. The Institutions' Computer Groups are holding a one-day conference on airborne computers at the School of Hygiene & Tropical Medicine, Keppel St., London, W.C.1, from 10.30 a.m. In the evening at 6.0 at the I.E.R.E., 9, Bedford Square, W.C.1, the Medical Electronics Group have arranged a meeting at which Dr. P. E. McGuff will present a paper on "Treatment of Experimental Animal and Human Malignant Tumours by Laser Radiation." Tickets obtainable from the I.E.R.E., are required for both meetings.

European A.T.C.—A computer-controlled system for the identification and tracking of civil aircraft is to be installed at the Eurocontrol Experimental Centre at Bretigny, France. The prime contractor is Elliott-Automation and the work will be carried out in conjunction with Standard Elektrik Lorenz (W. Germany), Ateliers de Construction Electronique de Charleroi (Belgium) and Cossor Electronics. The new A.T.C. scheme for the U.K. described elsewhere in this issue may well form part of the overall Eurocontrol in the not-too-distant future. By July 1st next year it will be compulsory for aircraft to carry transponders for use with the secondary radar system.

Radio Interference in America.—Authority to prohibit the production of electronic or electrical devices which might cause radio interference has been requested by the Federal Communications Commission, but the Electronic Industries Association has asked the Senate Communications Subcommittee to delay legislation until the F.C.C. and representatives from industry can discuss alternative methods of solving radiation-interference problems.

Frequency Tolerance of Aircraft Transmitters.—The I.T.U. Radio Regulations (Geneva) 1959 require that, as from January 1st, 1966, the carrier frequencies of all aircraft transmitters operating in the band 118 to 136 Mc/s be maintained to within 50 parts in a million of the selected channel. However, an analysis made by the Ministry of Aviation reveals that the number of transmitters operating outside the stipulated tolerance is insignificant and equipment with a frequency tolerance of 100 parts in a million may remain in use until further notice. Should a particular type or types of equipment consistently fail to meet the I.T.U. requirements, remedial action will be called for.

Guide to Electronic Equipment.—The Industrial Control and Electronics Division of B.E.A.M.A. has issued the first edition of a "Guide to the Specification and Purchase of Electronic Equipment for Industrial Systems." In the past, lack of general specifications for industrial electronics equipment has sometimes resulted in the use of specifications which may be inappropriate or unnecessarily costly. The guide will assist both customers and manufacturers by specifying standard types of equipment to meet the requirements for various applications and discusses other factors which need to be considered by both contracting parties. Priced at one guinea, the guide is available from the British Electrical & Allied Manufacturers' Association, 8 Leicester Street, Leicester Square, London, W.C.2.

Requirements for R.F. Connectors.—Part 1 of the International Electrotechnical Commission Publication 169, "Radio-frequency connectors," has recently been issued. Relating to connectors for r.f. transmission lines for use with electronic equipment, the publication establishes uniform requirements for electrical, climatic and mechanical properties, test methods, interchangeability and compatibility of connectors and connectors with cables. Price £3 from British Standards Institution, Sales Branch, 2 Park Street, London, W.1.

U.K. Kompass, a detailed register of British industry, is available in three volumes (£15 15s the set) from Kompass Register Ltd., R.A.C. House, Lansdowne Road, Croydon, Surrey. Two volumes list suppliers of more than 33,000 products manufactured in the U.K. The third volume details the location, products, share capital, directors, number of employees and other information of over 24,000 manufacturing companies.

Sound and Vibration Research.—The Science Research Council has made a grant of £228,200 to the University of Southampton towards the cost of research in sound and vibration under the direction of Professor E. J. Richards, director of the Institute of Sound and Vibration Research. Part of the grant relates to the provision of acoustic chambers and an audiology laboratory.

The Hungarian Society for Optics, Acoustics and Film-techniques is organizing a second conference on **Magnetic Recording** to be held in Budapest between October 11th and 15th, 1966. Papers on the subjects of static magnetic memories and recording on moving magnetic media are invited for inclusion in the conference programme. Further details can be obtained from the society—Optikai, Akusztikai és Filmtechnikai Egyesület, V, Szabadság tér 17, Budapest.

R.T.E.B.—The Radio Trades Examination Board this year celebrates its 21st anniversary. During the 21 years it has examined over 22,000 candidates for its certificates in radio and television servicing.

The series of articles, **Elements of Transistor Pulse Circuits**, by T. D. Towers, which appeared in *Wireless World* during 1964, has been used as a basis for a book of the same title published by Iliffe Books Ltd., price 35s.

Two Years in Space.—July 26th marked the second year in space of Syncom II, the world's first synchronous communications satellite. Hughes Aircraft Company who designed and built the satellite report that Syncom II stationed above the Indian Ocean has received and transmitted voice and teleprinter messages for an average of 13 hours a day. It has been in use for a total of 9,508 hours and has travelled more than 119 million miles in orbit.

Ghana's television service, comprising three transmitting stations at Accra, Kumasi and Sekondi-Takoradi, was officially opened by President Nkrumah on July 31st. The three stations, which serve approximately one quarter of the country, have central studios in the capital. The service, which operates in Band I on 625 lines (7 Mc/s channels) with f.m. sound, was a "turnkey" project of the Marconi Company. Ghana's external sound services have been extended by the installation of two Marconi 250-kW h.f. transmitters at Ejura where there are also six 10-kW h.f. transmitters for internal sound broadcasting.

American production of **colour TV receivers** in April this year was nearly double that of April 1964. The figures are 179,321 compared to 92,318, an increase of 94%. Although April output was down on the March figure of 205,577 the total production for the first four months of this year was 682,178 compared to 378,545 for the same period last year, an increase of 78%.

Air Defence for Three NATO Countries.—To control the air defences of Belgium, the Netherlands and West Germany the individual governments have selected the Tactical Air Weapons Control System (T.A.W.C.S.) designed by the Hughes Aircraft Company of Fullerton, California. In order to obtain NATO council approval for modernization of their air defence control system, the three countries formed an international planning group. The system provides the countries with not only collective air defence but also individual facilities for the rapid detection, identification and tracking of potential enemy air threats. Ground installation equipment supplied with the system includes communications, electronic displays, computers and data processing units.

New Colour Film from C.O.I.—Aspects of the technology of microelectronics are dealt with in the film "Thin-film Microcircuits" released by the Central Office of Information. The progress of a circuit is followed in this Mullard film from the design stage to the finished product, together with a description of evaluation and final testing. Running time 15 minutes; available on free loan from Central Film Library, Government Building, Bromyard Avenue, Acton, London, W.3.

1966 I.E.A. Exhibition.—The next International Instruments, Electronics and Automation Exhibition will be held at Olympia from May 23rd to 28th, 1966. Bookings are 15 per cent up on the 1964 exhibition in which 148 exhibitors out of 729 came from overseas.

German Radio Show Stamp.—30 million copies of a special stamp are to be printed featuring the German Radio Show which will be held in Stuttgart from August 27th to September 5th. The design depicts the Stuttgart TV tower surrounded by symbolic radiations.

The ninth B.R.E.M.A. exhibition of **cabinet styling accessories** will be held at the Hotel Russell, London, W.C.1, from September 28th-30th. It will be open each day from 2 to 6 p.m. and admittance is by invitation or business card. There will be 48 exhibitors.

The **Council of Engineering Institutions**, formerly the Engineering Institutions Joint Council, has moved to 2 Little Smith Street, Westminster, London, S.W.1. (Tel. SULLivan 3912-4.)

PERSONALITIES

G. D. Speake, M.A. (Cantab), A.M.I.E.E., appointed Director of Research for the Marconi Company, has since 1962 been chief of research at the Great Baddow Research Laboratories



G. D. Speake

and Development manager for the Radar Division. Mr. Speake, who is 45, took his degree in physics at St. Catharine's College, Cambridge. He joined the Marconi Company in 1950 and was engaged in radar systems research until 1954 when he was appointed chief of the vacuum physics section of the Research Division. Two years later he became chief of the microwave physics section. Before joining Marconi, Mr. Speake was a Flight Lieutenant in the Technical Branch of the R.A.F. and later, instrument manager at the Plastics Division of I.C.I.

Following the acquisition by Marconi Instruments of W. H. Sanders (Electronics) Ltd., **Professor H. M. Barlow**, F.R.S., and **Dr. E. Eastwood**, C.B.E., have been appointed to Sanders' board. Dr. Barlow is Pender Professor of Electrical Engineering at University College, London, where, except for war service, he has been on the academic staff since 1925. During the early part of the war he worked on the development of radar at the Telecommunications Research Establishment and in 1943 was appointed superintendent of the Radio Department at the Royal Aircraft Establishment, Farnborough. Dr. Eastwood joined the English Electric Group at the Nelson Research Laboratory, Stafford, in 1946, where he was in charge of radiation studies. Two years later he was appointed deputy chief of research with Marconi's at Chelmsford, and subsequently became Director of Research. Dr. Eastwood has been primarily engaged in research in the field of molecular constitution and in the application of radar techniques to the investigation of celestial noise and the detection of meteors.

Harold Peterson, who has been in Australia since 1960 as managing director of both British Automatic Telephone & Electric Co. Ltd., and Communication Systems of Australia Pty. Ltd., as well as a director of other Australasian companies, has been appointed chief executive of the Plessey Company's South African Region. Plessey's interests in the region include the Instrument Manufacturing Corp. of South Africa which produces the Tellurometer radar surveying instrument. Mr. Peterson, who is 46, began his career with the G.P.O., was in Royal Signals throughout the war, then with Cable & Wireless for eight years before joining A.T. & E. which is now part of Plessey.

F. W. Stoneham, M.B.E., Ph.D., B.Sc.(Eng.), A.M.I.E.E., who recently joined Creed & Company (makers of teleprinting and data processing equipment) as managing director has also been appointed a director of ITT Europe Inc. Dr. Stoneham is a graduate of University College Nottingham and was in the Royal Corps of Signals from 1939 until 1954 when he retired with the rank of Lt. Colonel. He was then with Smiths Aircraft Instruments until 1959 when he joined Ultra as chief engineer. He was managing director of Ultra Electronics when he left in May this year.

Geoffrey F. Meakes, who has been with the Racal Organization in the U.K. since 1951 and was responsible for a large part of the development of the famous Racal RA.17 communications receiver, has become chief engineer of Racal Communications Inc., of Silver Spring, Maryland, U.S.A. He was intimately associated with setting up Racal Communications Inc., and Racal (Canada), Ltd.

W. R. Parkinson, founder of the original Radio Gramophone Development Company has retired. When the R.G.D. factory at Bridgnorth became A. T. & E. (Bridgnorth) Ltd. he became technical director and he is here shown (left) being presented with a pair of binoculars by E. J. Bartlett, manager of A. T. & E. (Bridgnorth)



Dudley Seward, O.B.E., managing director of Rank-Bush Murphy for the past four years, has been appointed general manager of the consumer products division of Standard Telephones & Cables in succession to **Gibson B. Kennedy**, who is returning to the United States. In his new position, Mr. Seward is responsible for the K.B., R.G.D., Regentone, Ace and Argosy brands of domestic sound and television equipment manufactured at Footscray (where he has his headquarters), Hastings and Rhyl. Mr. Seward, who was at one time managing director of Texas Instruments Ltd., is a member of the P.M.G.'s Television Advisory Committee.



D. Seward

E. C. J. Jezierski has been appointed chief engineer of Radio Communications Co., of Crewkerne, Somerset. Previously he was research director with Derritron Research Development Ltd., where he was concerned with the design of telecommunications, telemetry and missile control equipment.



Air Cdre. Lionel H. Greenman, C.B.E., who has been senior air staff officer, R.A.F. Signals Command since May last year, has been transferred to technical operations at the Maintenance Command H.Q. Air Cdre. Greenman, who is 50, was a Post Office engineer before joining the R.A.F.V.R. in 1936. In 1943 he went to America and became deputy director of technical requirements with the R.A.F. Mission in Washington. For two years from 1959 he was commanding No. 30 Maintenance Unit, R.A.F. Sealand, Cheshire. He is succeeded as senior air staff officer at Signals Command by **Air Cdre. John Goodman**, M.I.E.R.E., who joined the R.A.F. in 1932 as an aircraft apprentice at No. 1 Electrical and Wireless School, Cranwell. During and since the war he has served at various bases at

home and overseas and at the Air Ministry. In 1962 he took command of the Radio Engineering Unit at R.A.F. Henlow and since 1963 has been commandant of the Central Signals Establishment.

J. R. Humphreys has become general manager of A. C. Cossor's Industrial Products Group. He will be responsible for the operations of the Cossor Instrument Co., Cossor Communications Co., Best Electrics and Cossor Valve Co. He succeeds **J. F. Eldredge**, who, after spending over three years at Cossor, is returning to Raytheon in the United States. Mr. Humphreys was, until recently, divisional manager of the Telecommunications Division of Elliott Bros. (London) Ltd., prior to which he



J. R. Humphreys

was for a number of years chief engineer of Pye Telecommunications.

"The Indefatigable Dr. Eccles"

90TH BIRTHDAY OF A LAST CENTURY PIONEER

A NAME to conjure with in the more elevated radio-technical circles during the first quarter of the present century was that of Dr. W. H. Eccles, F.R.S., who recently celebrated his 90th birthday. His name recurred constantly in *Wireless World* during its early years.

William Henry Eccles was born at Ulveston, Lancs., on 23rd August, 1875. It would hardly be too much to say he became the first of the radio physicists, though he has to his credit many contributions to the technology of the art. He came near to being a founder member of the world's first wireless company, the Wireless Telegraph and Signal Co., eventually to become the Marconi Co., which he joined in 1899—during Queen Victoria's reign! That was a year after the firm started at the Chelmsford works. Armed with an Honours B.Sc. in physics, gained the year before from the Royal College of Science, he started work on the design of oscillation transformers or "jiggers," as they were called, for the new tuned sets that were just coming in. He also started a study of the coherer, the only detector of the period, which led to a better understanding of the action of that temperamental device. Then, after a short spell as editorial assistant on *The Electrician*, he changed over to teaching electrical engineering, physics and mathematics. Whenever opportunity offered he did radio research.

What was probably Dr. Eccles's most significant work was on a subject at the very heart of our affairs—on radio wave propagation. In 1911 he published a Royal Society paper explaining and expanding the theory put forward by Oliver Heaviside some ten years earlier and since then largely forgotten or ignored. Heaviside had tentatively said "there may possibly be a sufficiently

conducting layer in the upper air. . . " Eccles now suggested that the ionizing effect of sunlight might account for observed differences between day-time and night-time transmissions. The subject, which was treated in greater detail later, aroused quite violent controversy but, by the end of 1912, when some support for his ideas came from observations made during a partial solar eclipse, the Eccles theory was widely accepted and solid foundations were laid for subsequent work by Appleton and others.

It would hardly be too fanciful to put forward Dr. Eccles as the grandfather of the transistor. In 1909 he demonstrated oscillating crystal detector circuits and developed the general theory "that under certain conditions a rectifying detector could become a generator of oscillations and conversely a generator of oscillations could be used as a rectifier."

One of his minor contributions was the proposal in 1919 of what has since become the universal valve nomenclature—diode, triode, heptode, etc. *Wireless World* may well blush with shame for having stigmatized that proposal of "the indefatigable Dr. Eccles" as being "too academic" for general acceptance. He was often ahead of his times.

When, just after the first World War, the project for a British "Imperial Chain" of long-wave stations was revived Dr. Eccles was appointed vice-chairman under Lord Milner of a Government committee to plan the details. Before the scheme came to fruition the "short-wave bombshell" was exploded but the long-wave Rugby station eventually started operation.

During his distinguished career he occupied many important posts and has accumulated an impressive list of honorifics. He is Past-President of the

Physical Society; of the Institute of Physics; of the Institution of Electrical Engineers; of the Radio Society of Great Britain and *President d'Honneur* of the International Radio Scientific Union (U.R.S.I.) of which he was a member almost from its beginnings.

Dr. Eccles recently talked about some of his little-known activities during the first World War. In 1915 he was invited to advise the War Office on radio matters and devised a short-wave transmitter with valves in push-pull capable of oscillating at the then unheard-of high frequency of 60 Mc/s. Sets to this design were tried by the French army for short-distance work, but the signals were heard as far away as Syria. That was the first indication that short waves had possibilities for long-distance working. At about the same time he devised a valve-maintained tuning fork for frequency control.

In 1917, when Professor of Electrical Engineering and Applied Physics at the City and Guilds Institute, he was appointed to the anti-submarine committee and the college laboratory was taken over by the Admiralty. Many applications of valves to underwater signalling and detection were developed.

After 1924, when Dr. Eccles suffered a severe illness, he was forced to confine his activities to private consultancy. He now lives in retirement on the South Coast. Happily, his health is now remarkably good except for failing eyesight and his memory exceptionally clear. In boyhood he spent some months in a Quaker community near the birthplace of Michael Faraday (whom he greatly admires) and there absorbed the faith to which he has since adhered. By reason of his beliefs, he has been reluctant to patent his inventions.

H. F. S.

Demonstration of Oscillatory Action

By T. PALMER,* B.A., Grad.I.E.E., Assoc.I.E.R.E.

IN a previous article¹, a description was given of a method for demonstrating the phase difference of currents flowing in a parallel arrangement of L, C and R. The signal source was an oscillator with a frequency of 5 cycles per minute and phase difference was demonstrated by the pointer movements of moving-coil centre-zero

meters. By using a double-beam cathode ray oscilloscope and an a.f. signal generator our demonstrations can be extended to display oscillatory action.

* Acton Technical College.

¹ "Demonstrating A.C. Theory," by T. Palmer, *Wireless World*, October 1963, p. 515.

Parallel resonance can be demonstrated by the circuit of Fig. 1. Suitable values are 30mH for the coil and 0.5 μ F for the capacitor. The A2 trace of the oscilloscope displays the generator voltage, and the A1 trace displays the voltage across the tuned circuit. By varying the frequency of the signal generator above and below the resonant frequency the effect of resonance can be displayed. At resonance the two traces are in phase and the voltage across the tuned circuit has maximum amplitude.

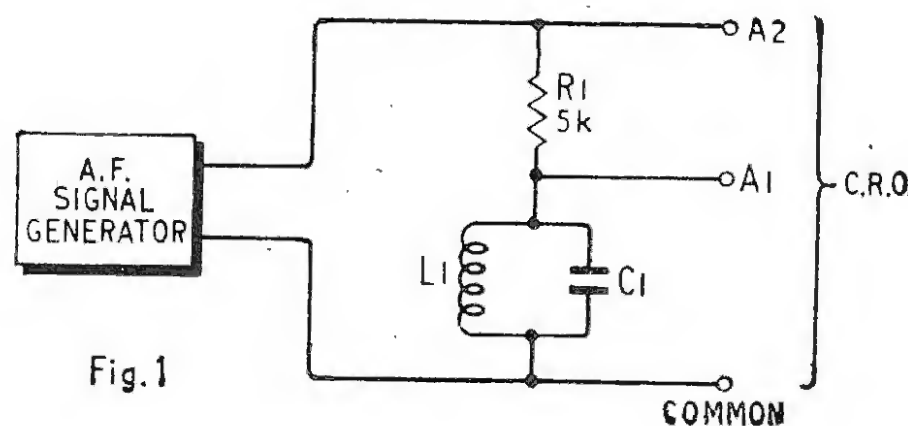
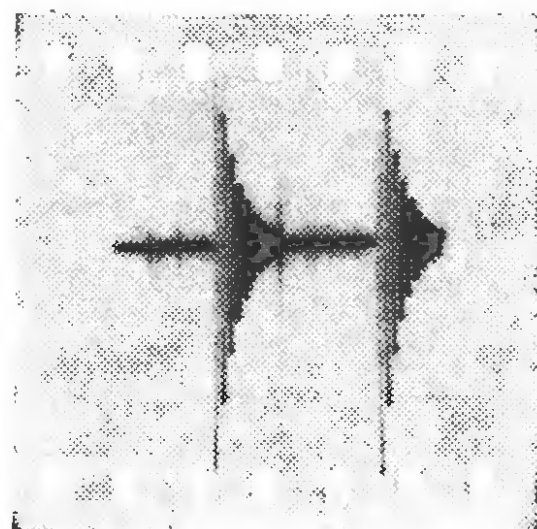

Fig. 1

We now take the circuit of Fig. 1 and modify it to that of Fig. 2. A change-over switch, S1, is operated by a



A

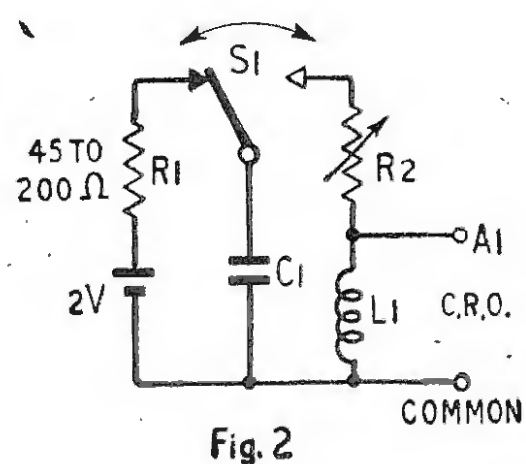
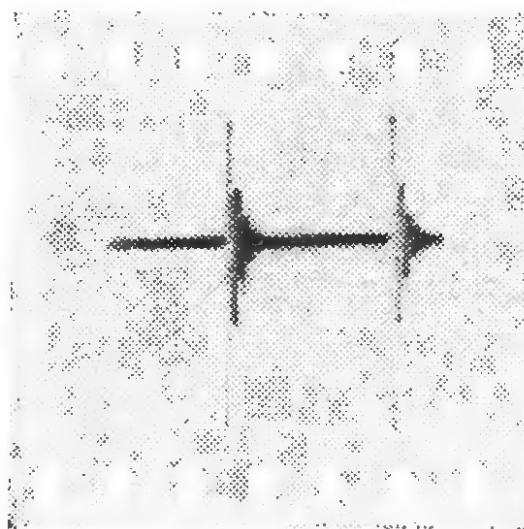

Fig. 2

Carpenter relay working at 50c/s. In one position of the switch, a 2-volt accumulator charges C1 through R1; in the other position, C1 discharges through L1 and R2, a variable resistor of 0-50 Ω . The waveform of the voltage across the coil is shown in Oscillogram A, with R2=0 Ω . With R2=30 Ω , the waveform is as shown in Oscillogram B. Having shown this waveform we reduce R2 to zero.



B

In Fig. 3, the coil L1 is connected in the input of a very simple transistor amplifier which has a coil, L2, of 30mH in the collector circuit. First, this coil is remote from L1, and, when the amplifier is switched on, there is no difference in Oscillogram A. However, as the

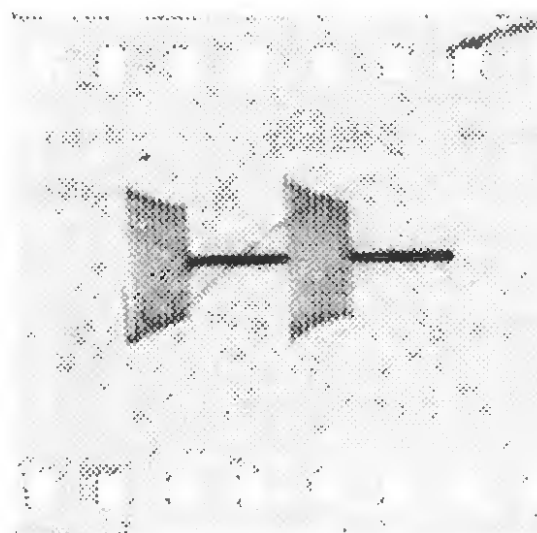

C

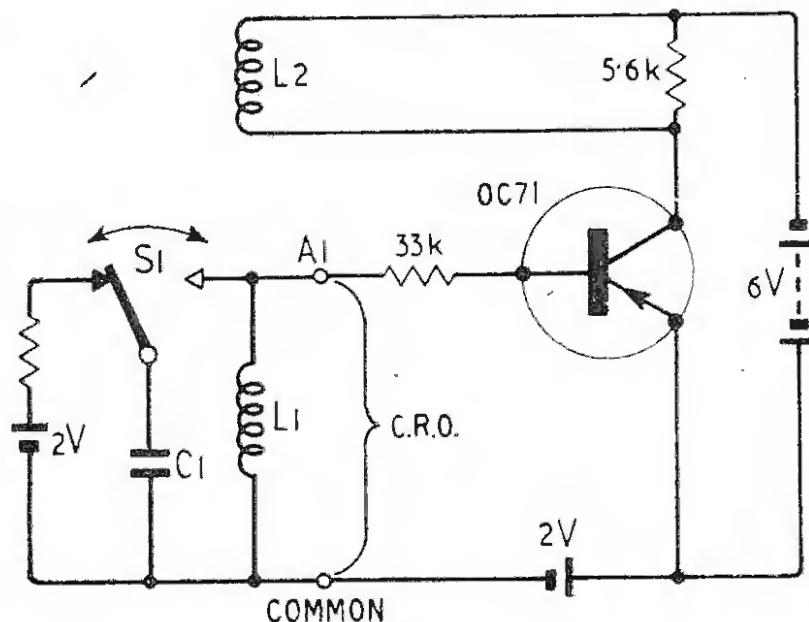
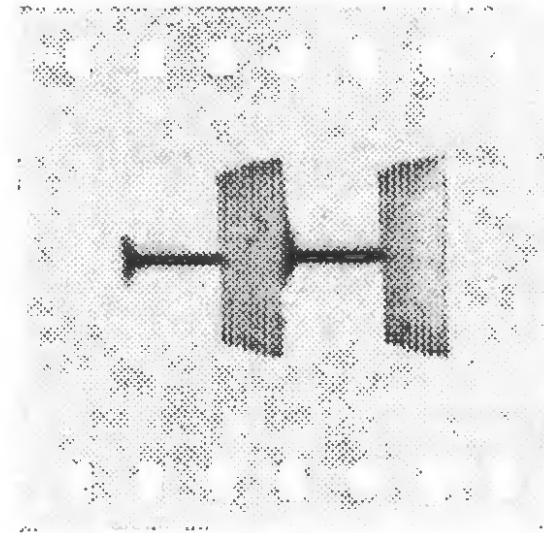

Fig. 3

collector coil L2 is advanced towards L1, the trace on the scope is seen to die away either more rapidly (as if the resistance R2 in Fig. 2 had been increased—negative feedback) or less rapidly (positive feedback). Whether we have the first effect or the second depends, of course, on



D

the way L2 is connected. Both effects should be shown in turn. With positive feedback, as L2 is advanced towards L1, the oscillation dies away less and less rapidly (as in Oscillogram C). With L2 still closer to L1, oscillations are seen to grow, as in Oscillogram D.

L2 is left in the position which produces increasing amplitude of oscillation, the Carpenter relay is disconnected and the coil is strapped permanently to the capacitor as shown in Fig. 4. Sustained oscillations are seen as in Oscillogram E and F (for F the time-base has been speeded up) showing that the parallel circuit of Fig. 1 has become part of an oscillator.

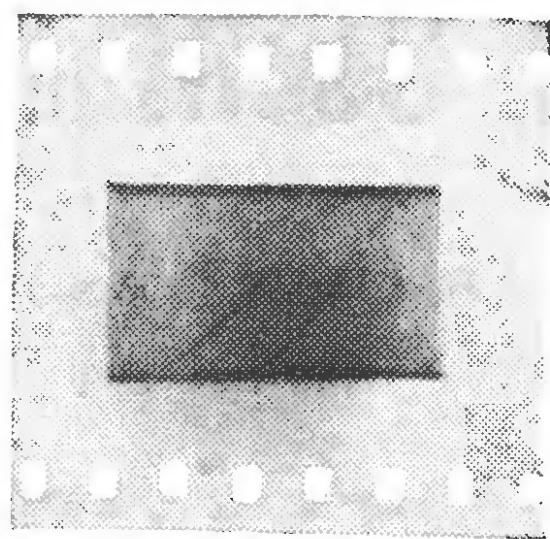

E

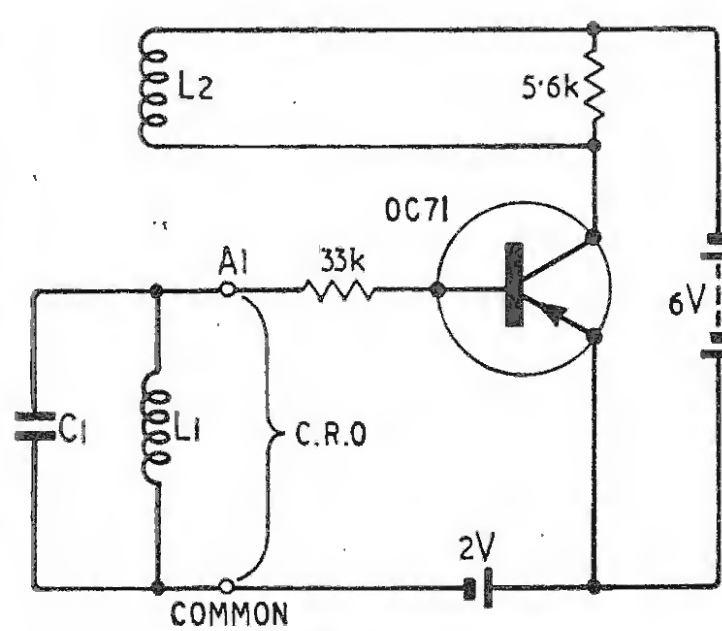
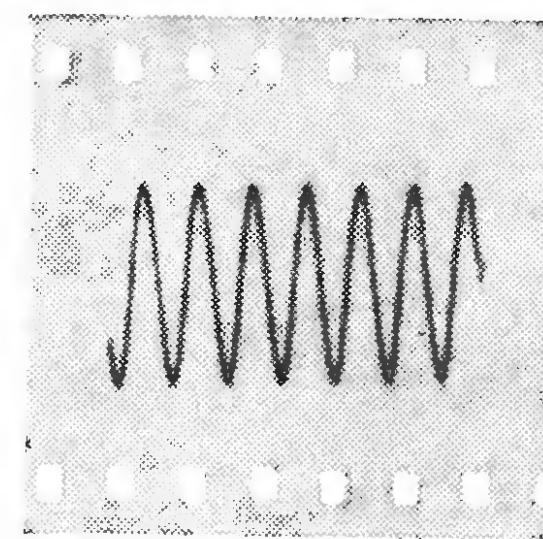

Fig. 4



F

It scarcely needs to be stressed that these demonstrations are intended only for elementary students although the last demonstration may help those who wish to study

the action of super-regenerative circuits. With conditions corresponding to those of Oscillogram D, try charging C1 from batteries of different voltages.

September Conferences and Exhibitions

Further details are available from addresses in parentheses

- | | | | |
|--|-------------------------|---|--------------------|
| LONDON
Sept. 13-17.
Engineering Materials & Design Exhibition
(Industrial Trade Fairs, 1-19 New Oxford St., W.C.1) | Olympia | SWANSEA
Sept. 21-23
Physics of Semiconducting Compounds
(Inst. Phys. & Phys. Soc., 47 Belgrave Sq., London, S.W.1) | University College |
| Sept. 13-17
Microwave Behaviour of Ferrimagnetics & Plasmas
(I.E.E., Savoy Place, W.C.2) | Savoy Place | OVERSEAS
Sept. 4-12
Italian Radio & TV Show
International Electronic Components Show
(A.N.I.E., via Luciano Manara 1, Milan) | Milan |
| Sept. 20-24
Thermionic Electrical Power Generation
(I.E.E., Savoy Place, W.C.2) | Savoy Place | Sept. 6-9
Opto-Electronic Components & Devices
(M. Coulmy, D.R.M.E., 7 rue de la Chaise, Paris, 8) | Paris |
| BRIGHTON
Sept. 28-Oct. 1
European Medical Electronics Symposium & Show
(Symposium Secretary, 4 Mill Street, London, W.1) | Hotel Metropole | Sept. 6-11
Electromagnetic Wave Theory
(Dr. R. Timman, c/o Technological University, Julianalaan 132, Delft) | Delft |
| CAMBRIDGE
Sept. 1-7
British Association Meeting
(British Assoc., 3 Sanctuary Bldgs., Great Smith St., S.W.1) | | Sept. 7-11
INEL—Industrial Electronics Exhibition
(Swiss Industries Fair, Postfach, Basle 21) | Basle |
| CRANFIELD
Sept. 20-24
Network Theory Symposium
(S. R. Deards, College of Aeronautics, Cranfield, Beds.) | College of Aeronautics | Sept. 7-14
International Congress on Acoustics
(5e Congrès International d'Acoustique, 35 rue Saint-Gilles, Liège, Belgium) | Liège |
| LIVERPOOL
Sept. 15-17
Nuclear and Particle Physics
(Inst. Phys. & Phys. Soc., 47 Belgrave Sq., London, S.W.1) | The University | Sept. 9-11
Industrial Electronics & Control Instrumentation
(L. Winner, 152 W42nd St., New York 52) | Philadelphia |
| MANCHESTER
Sept. 6-10
Materials & Environmental Testing
(Inst. Mech. Engrs., Birdcage Walk, London, S.W.1) | Col. of Science & Tech. | Sept. 9-19
International Radio & TV Salon
(F.N.I.E., 16 rue de Presles, Paris 15) | Paris |
| Sept. 7-9
Internal Friction in Solids
(Inst. Phys. & Phys. Soc., 47 Belgrave Sq., London, S.W.1) | The University | Sept. 14-Nov. 12
I.T.U. Plenipotentiary Conference
(International Telecom. Union, Place des Nations, Geneva) | Montreux |
| Sept. 28-Oct. 2
Electronics, Instruments & Components Show & Convention
(Institution of Electronics, 78 Shaw Rd., Rochdale, Lancs.) | Belle Vue | Sept. 17-19
International Ham Convention
(L. Vervarcke, Lippenslaan 284, Knokke, Belgium) | Knokke |
| OXFORD
Sept. 5-11
Electromagnetic Distance Measurement
(Royal Society, 6 Cornwall Terrace, London, N.W.1) | | Sept. 17-26
Firato Electronics Exhibition
(RIA, Europaplein 8, Amsterdam) | Amsterdam |
| SOUTHAMPTON
Sept. 21-23
Applications of Microelectronics
(I.E.E. Symposium, The University, Southampton) | The University | Sept. 17-Oct. 3
British Exhibition
(British Overseas Fairs, 21 Tothill St., London, S.W.1) | Tokyo |
| | | Sept. 21-23
Conference on Magnetism
(Verein Deutscher Eisenhüttenleute, Breite Str. 27, Düsseldorf) | Vienna |
| | | Sept. 22-24
Military Electronics Convention
(I.E.E.E., Box A, Lenox Hill Station, New York 21, N.Y.) | Washington |

LETTERS TO THE EDITOR

The Editor does not necessarily endorse opinions expressed by his correspondents

Transistor Cascade Crystal Oscillator

IN my article in the July issue there is a mis-statement in the paragraph under the heading "The Bootstrap Cascade Circuit". The offending sentence reads: "Both transistors are used in the common-base connection, though this may not be apparent from the circuit diagram." The wording should read: "Tr₂ is used in the common base connection while Tr₁ is a common collector stage which acts as the collector load impedance of Tr₂".

My attention was drawn to this slip by a young reader, Mr. C. Marcus, of Ashted, Surrey, who pointed out in a well-reasoned letter that there is no alternating potential on the collector of Tr₁. He went on to justify his comments by re-drawing the circuit to illustrate the a.c. conditions more clearly and finally he built circuits and obtained both sinusoidal and relaxation oscillations at will.

My description of the functions of Tr₁ was perhaps too brief but the point had been more fully covered in an earlier article on "Transistor Wide-Band Cascade Amplifiers" (March 1965). Some further explanation is required. If in Fig. 4 of my July article the quartz crystal, the feedback diodes and their associated capacitors are removed, we are left with two series-connected transistors and their bias networks. If an alternating signal voltage is applied to the emitter of Tr₂ it acts as an earthed-base amplifier. Its complex collector load is formed by Tr₁, R₁, R₂, R₅ and C. If C is large, or if its reactance is low at the signal frequency, the alternating output voltage of Tr₂ appears at the base of Tr₁, across R₁. If the output is taken from the emitter of Tr₁, it is at low impedance since this transistor is acting as an emitter follower. At the same time Tr₁ and its associated components simulate a very high-impedance collector load for Tr₂, giving a large voltage gain, without calling for an excessive supply voltage. A limit to the load impedance is in fact set by R₁ which (with large C), is effectively in parallel with the load presented by Tr₁ and R₅ in series. High gain thus calls for a high value of R₁, with proper selection of R₂, R₃ and R₄ to maintain the correct operating bias. To sum up, Tr₁ acts simultaneously as a high-impedance load as seen from Tr₂ and also as an output stage of low impedance to any load connected to its emitter terminal.

Finally, I mentioned the possibility that the new crystal oscillator might be suitable for development into a high-grade frequency standard. Readers interested in this topic are referred to a recent paper by P. J. Baxandall, "Transistor Crystal Oscillators and the Design of a 1 Mc/s Oscillator Circuit of Good Frequency Stability", *Radio and Electronic Engineer* (I.E.R.E.), Vol. 29, No. 4, April 1965, p.229. It takes a new look at some well-established oscillator circuits, re-drawing them to suggest a fresh analytical approach, makes a critical comparison of the Pierce and Miller circuits and finally gives details of a new series resonance oscillator of high performance.

Although many designs for stable crystal oscillators have been published, some actually going into details like component values, nearly all have the weakness that no reasons are given for the choice of the techniques actually used. In this respect Peter Baxandall's paper is outstanding. It provides a wealth of unique information

to the designer of such equipment, for whom it is not too much to say that the paper is indispensable.

Cheltenham, Glos.

F. BUTLER

Units

MR. GIBBS writing again on this subject at considerable length in the August issue, dismisses my first three points (April issue, p.196) as matters merely of convenience rather than principle. Is convenience not then important? Yet paradoxically he himself raises a point of convenience in conjuring up a fanciful picture of SI advocates trying to persuade semiconductor specialists to measure the volume of germanium in cubic metres. Does he really suppose that I or anyone else would spend our time campaigning for the statement of inter-electrode capacitances in farads? The SI system does not exclude the well-known set of multiples and submultiples. Incidentally, I disposed of this argument in my original article.

Mr. Gibbs is just as wrong in his closing sentence suggesting, on no evidence at all, that I wish to enforce any system of units by legislation. He must be running short of arguments to have to invent Aunt Sallies to hit out at. He also ignores my point (6), which is a matter of principle.

The first argument in his letter seems to be based on the premise that what a lot of people have done must be right. Are there no such things as enlightenment and progress?

I do not intend to waste space by arguing the essential difference between H and B, when it has been done by writers of much greater authority whose works are on record for Mr. Gibbs or others sufficiently interested.*

Mr. Gibbs undermines his own case against electrical charge being basically one quantity, whether reckoned in e.m. or e.s. c.g.s. units, by his arguments for the identity of H and B. If he can believe that electric charge is fundamentally two quantities at the same time as believing H and B are fundamentally one quantity he can believe anything. And then he goes on "From the atomic point of view, then, a distinction between the units of B and H is a considerable inconvenience," when he has already dismissed convenience as too unimportant to discuss compared with principle! Incidentally, I have recently written a book on atomic electronics without being conscious of the inconvenience mentioned. Neither, apparently, were the physicists Bleaney and Bleaney in their very successful textbook on electricity and magnetism from the modern point of view (now in its second edition), written throughout in m.k.s.a. units.

I do seem to have based my appeal to Maxwell on an incomplete reading of the context, and am obliged by Mr. Gibbs to conclude that on this matter he has been proved wrong, as he admittedly has been with regard to his Art.501 which states that magnetic force acts on the conductor, not the current.

I am fairly sure that arguments in favour of the c.g.s.

* E.g.: C.W.O.H., "Wireless Engineer", Feb. 1933 p. 61; Apr. 1933, p. 179 Dec. 1949, p. 383; etc.
Sir J. J. Thomson, "Elements of Electricity and Magnetism" 5th edn., (1921), Art. 153.
O. Heaviside, "Electromagnetic Theory," Vol. 1, Arts. 20-23.

systems made now will look rather quaint to our successors in the not very remote future.

“CATHODE RAY”

Radiation from Class D Amplifiers

IN the July issue of *Wireless World* Mr. F. Butler pointed to the problem of radiation caused by class D amplifiers. The radio frequency interference produced by the carrier and its harmonics can indeed be quite objectionable if no special precautions, such as low-pass filters or screened and twisted loudspeaker leads, are used. The design of such filters, however, is particularly difficult as the introduction of linear frequency-dependent circuits may cause non-linear distortion of a different nature than already discussed for purely inductive loads. To understand this phenomenon it is necessary to know more about the high-frequency components of p.w.m.

The rectangular waveform shown in Fig. 1, having a

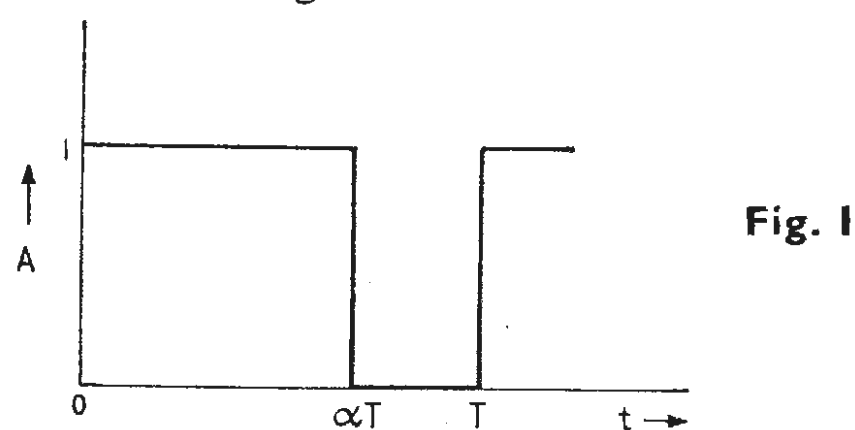

variable mark-space ratio denoted by α , can be represented by:

$$F(s) = \frac{1}{s} \frac{1 - e^{-\alpha s T}}{1 - e^{-s T}}$$

where T is the duration of one period. Apart from the low-frequency component which is intended to flow through the load it can be shown that the high-frequency components (first and higher order harmonics) are given by:

$$F_h(t) = \frac{1}{\pi} \sum_{n=1}^{\infty} \frac{1}{n} \left\{ \sin(n\omega t - 2n\pi\alpha) - \sin n\omega t \right\}$$

$$\text{or } F_h(t) = \sum_{n=1}^{\infty} \frac{\sin n\pi\alpha}{n} \cos(n\omega t - n\pi\alpha)$$

where ω is the angular velocity of the p.w.m. repetition rate (first harmonic) and n is the order of each harmonic. This formula shows that each component is phase modulated and that the modulation index for each component is proportional to its order. Further the amplitude of each component is inversely proportional to n , and varies with the mark-space ratio α as given in Fig. 2.

Thus, when the pulse width is modulated, simultaneous amplitude and phase modulation of each component occurs in such a fashion that the pulse width corresponds uniquely to the amplitude and phase relationship given by the formula. When this relationship is distorted by a low-pass filter having an improperly designed amplitude and phase characteristic, the pulse width at the output will be altered with respect to the p.w.m. at the input. Although generally this distortion will be non-linear (depending on the characteristics of the filter) it is of no consequence as long as the load is a purely linear element. This is because the high-frequency components contain no d.c. or l.f. component and will average out in a normal loudspeaker.

The situation is different when part of the energy at the input of the filter is reflected back into the output stage.

In the properly designed filter the prescribed relationship between the harmonics is maintained and only loss of efficiency may occur. However, if this is not the case, a superposition of two signals, only related by the filter characteristics, is presented to the highly non-linear output stage and gives rise to modulation effects. The result is not only non-linear distortion of the audio signal (depending on the transistor switch characteristics as already discussed in these pages) but also beat products between the high-frequency components themselves. This last effect is particularly objectionable, since the beat product of the harmonics of the 2nd and 3rd order then not only produces a non-linearly distorted audio signal but may again beat against the first harmonic, producing more distortion. This type of distortion is unique to the class D amplifier and cannot be compared to that produced by the more conventional classes

As transistor switches are not the ideal generators to match filters to, it is advisable that the group delay of the filter is constant over a sufficiently large range to ensure that the energy of reflected harmonics is low enough when the prescribed relationship between them is lost. This is not true for all types of loudspeaker, so one should be careful in selecting a suitable reproducer.

Much has been said in these pages on the subject of p.w.m., but it seems less known that a class D amplifier driven by a f.m. signal is equally capable of producing audio amplification. The only difference between the two methods is that f.m. differentiates the modulating signal if the modulation index is independent of the frequency of the modulating signal, whereas p.w.m. does not. In a properly designed f.m. audio amplifier the audio signal should therefore be integrated before modulation. This effect explains why, in the case of, e.g., the closed loop p.w.m. amplifier, the distortion introduced by the limited p.w.m. can be compensated by frequency modulation of the p.w.m. repetition rate—or, as Mr. K. C. Johnson put it in the May issue: “might not the feedback . . . ‘know’ that a judicious amount of f.m. can actually reduce the troublesome l.f. sidebands?” However, it will be clear that a suitable filter for f.m. is even more difficult to design than for a fixed repetition rate.

Finally, it seems surprising that the more conventional circuits for producing p.w.m. as used in telemetry, etc., have not been discussed. As so many readers are vividly interested in the subject, a fairly simple circuit is given in Fig. 3 which needs little explanation. A symmetrical driver feeds a flip flop modulator (2N1304), which in turn drives directly the symmetrical output stage. The transistors in this last stage are driven hard so that extra

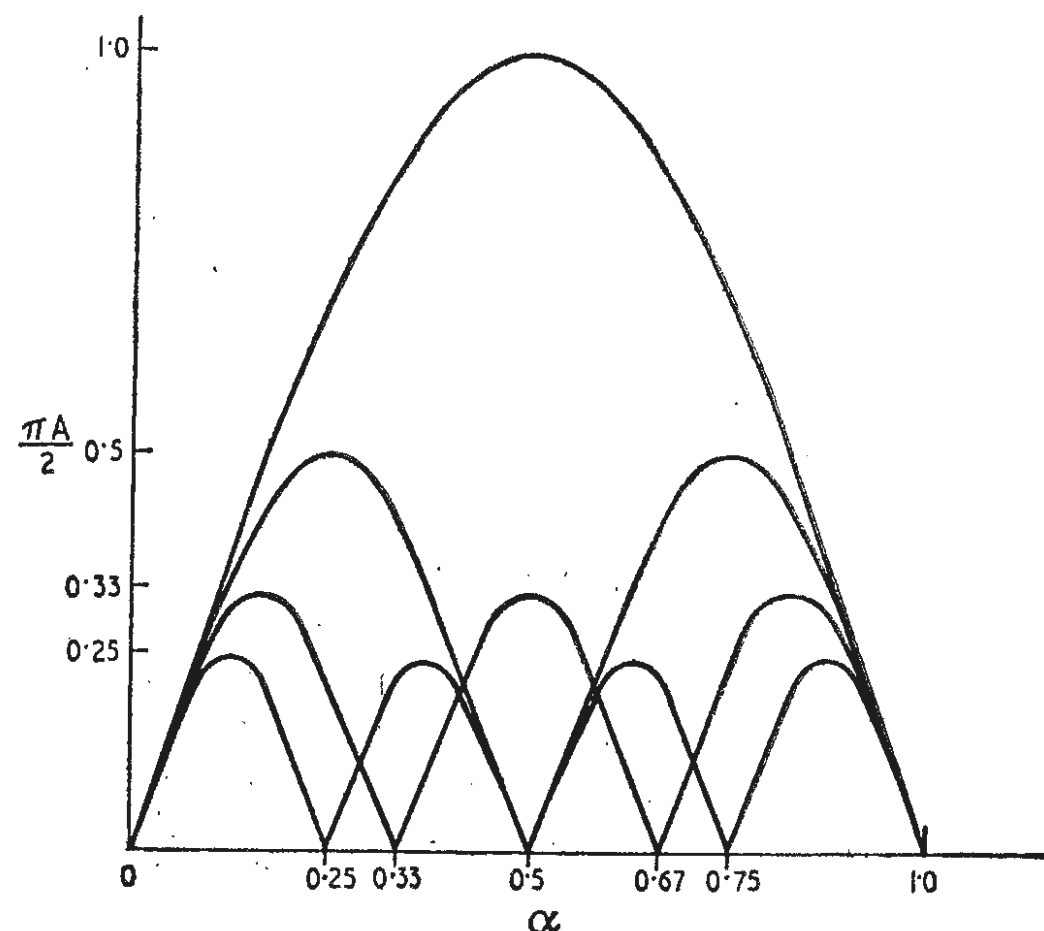

Fig. 2

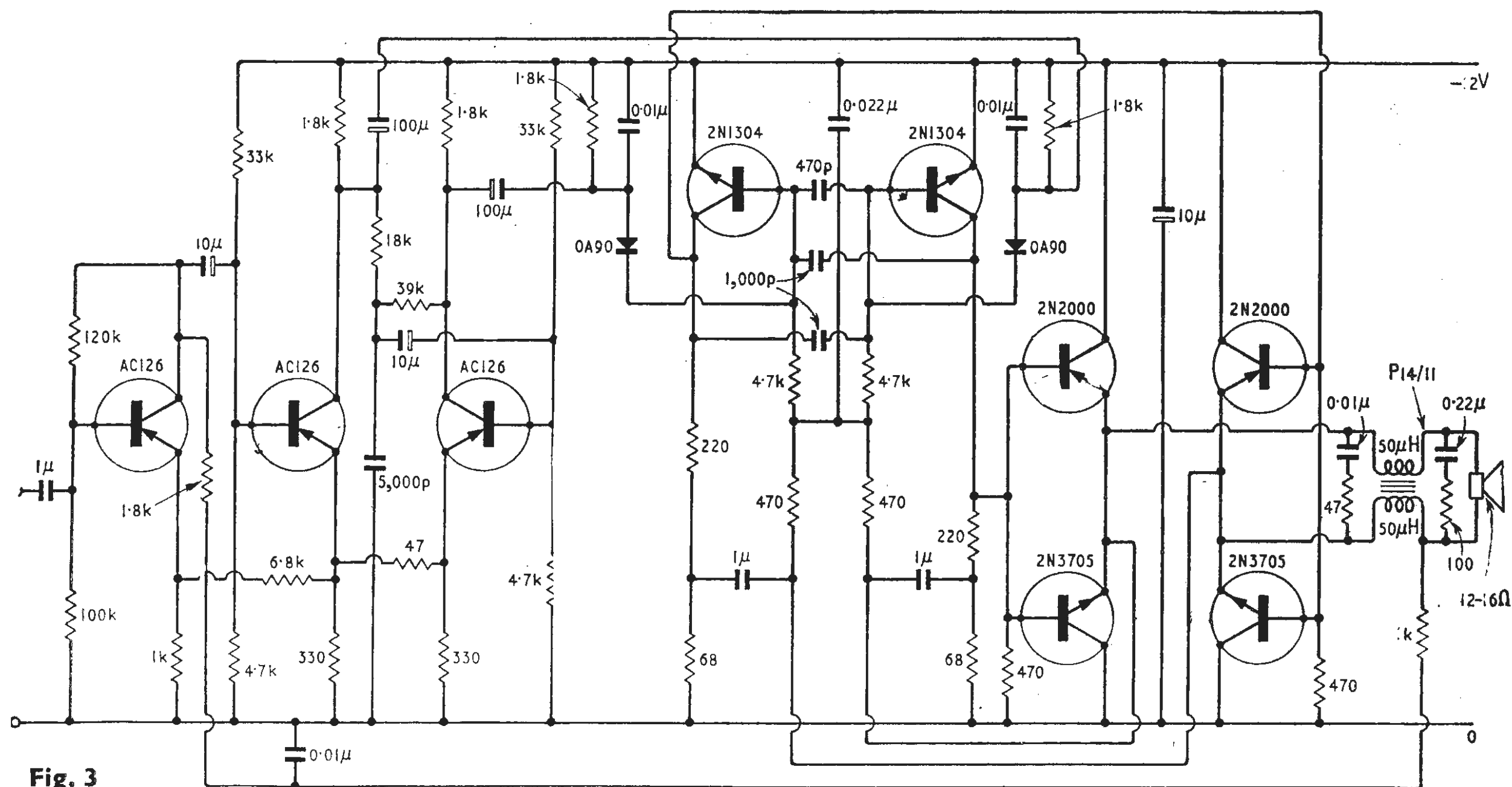

Fig. 3

diodes to provide alternative paths are not necessary. Furthermore, the simple (but by no means optimum) filter is damped to reduce the reflected energy.

Amsterdam.

D. BOSMAN

Satellites & TV Standards

YOUR editorial in the August issue has, rightly, raised the problem of television standards and the use of synchronous satellites. May I suggest that a possible solution offers itself, if we have the courage to accept the fact that the new u.h.f. television service for the U.K. is obsolete before it has got off the launching pad?

The plan for the u.h.f. service is, by now, well known. The country is to be covered by a number of high-powered transmitters, with a number of low-powered "fill-in" stations to cater for the low-lying and badly shadowed regions. A capital expenditure of some £100 million will be involved.

It has recently been announced that a satellite housing a high-powered transmitter can be put into orbit and it is, surely, more practical (and very much cheaper) to use such a satellite to broadcast the country's television service. The satellite could be commissioned and put into orbit for, probably, less than £20 million, and maybe it could be simplified by being engineered for this exclusive use. Existing problems of co-channel and similar interference would not arise, neither would those due to propagation over the earth's surface.

The satellite signal frequencies would, of course, need to be very much higher than the u.h.f. band in order that a high-gain aerial of modest dimensions could be used at the receiver. Existing receivers need not, however, be made obsolete; a frequency converter could be fitted either as part of the aerial installation, or at the receiver.

If we used such a system it would, of course, provide "free" television programmes to a large proportion of the earth's surface. Herein lies a particularly attractive aspect of the system. We could "go-it-alone" with the reasonable assurance that viewers in other countries will wish to see these "free" programmes. It is probably too

much to hope that such a venture could be a combined European operation in its early stages.

Is it too late to re-cast the country's television service into a sophisticated system that could be far in advance of any other? It could give receiver manufacturers the "shot-in-the-arm" they so desperately need.

R. S. ROBERTS

The Northern Polytechnic,
London, N.7.

FURTHER EDUCATION

THE following courses to be held at various centres during the forthcoming academic year have been selected from information received as being of particular interest to *Wireless World* readers.

Twickenham College of Technology.—In addition to part-time courses leading to the O.N.C. and H.N.C. with endorsements for the graduateship examinations of I.E.E. and I.E.R.E., special lecture courses are available on fundamentals of semiconductor devices, transistor circuit design, basic electronics, network analysis and basic principles of systems analysis.

Full-time and part-time post-graduate courses in electrical engineering leading to the internal M.Sc.(Eng.) degree of the University of London commence on September 27th at **West Ham College of Technology**, London, E.15. Evening courses for post-graduates include semiconductor device design, semiconductor circuit design theory and linear network theory.

Among the subjects dealt with by special evening lecture courses at **Hendon College of Technology** are an introduction to microwaves, introduction to automatic computing techniques in industrial applications, transistors and transistor circuit design, and high-fidelity sound reproduction.

The prospectus from the **Northern Polytechnic**, London, N.7, gives details of full-time and part-time degree courses together with a professional course leading to a diploma exempting students from the graduateship examination of the I.E.R.E.

Bristol Technical College is offering a two-year full-time course in aircraft radio and electronics as well as courses for the P.M.G.'s certificates for marine radio officers.

Brighton Technical College.—Part-time courses and block release courses for technicians are outlined in the Engineering Department's prospectus "A."

Post-graduate laboratory courses at **Portsmouth College of Technology** include a ten-evening course on the analysis and simulation of control systems and another on microwave measurements.

Semiconductor Detectors for Nuclear Radiation

By J. B. DANCE, M.Sc.

If α , β or γ -radiation is absorbed by matter, the energy is dissipated in the formation of ions and excited atoms. With application of a suitable electric field, the ions may be collected at the electrodes and the resulting pulse used to operate a scaler or ratemeter. In some forms of detector (ionization chambers, proportional and Geiger-Müller counters) the ions are formed in a gas, but during the past few years much effort has been expended on solid-state ionization chambers, partly because a solid absorbs energy from penetrating radiation far more effectively than a gas. A particle which will travel 1 metre in air can be absorbed by about 1 mm of silicon. Particles are absorbed in a solid in scintillation counters, but the process by which the energy of the particles is converted first into photons and then into

energy of a γ -ray is shared with an electron; the electron is given a high velocity and a γ -ray of lower energy is formed. The γ -ray may undergo further Compton scattering, but is more likely to escape unless the volume of the absorber is large. Radiation exceeding 1.02 MeV can cause electron-positron pair production. The positron will meet another electron and the two will be annihilated, two γ -rays (about 0.51 MeV) being formed.

In Compton scattering and pair production it is likely that a large fraction of the energy of the γ -ray will escape the absorbing material. If a γ -photon is absorbed by the photoelectric process, however, the whole of the energy of the photon is absorbed. Thus if a detector is used which produces output pulses of an amplitude proportional to the energy absorbed, the amplitude of these pulses will be proportional to the energy of the incident γ -radiation only if the absorption occurs by the photoelectric process.

The photoelectric absorption coefficient is proportional to the fifth power of the atomic number of the absorber. Thus if it is necessary to determine the energy spectrum of γ -photons, it is desirable that the absorbing material should have a high atomic number.

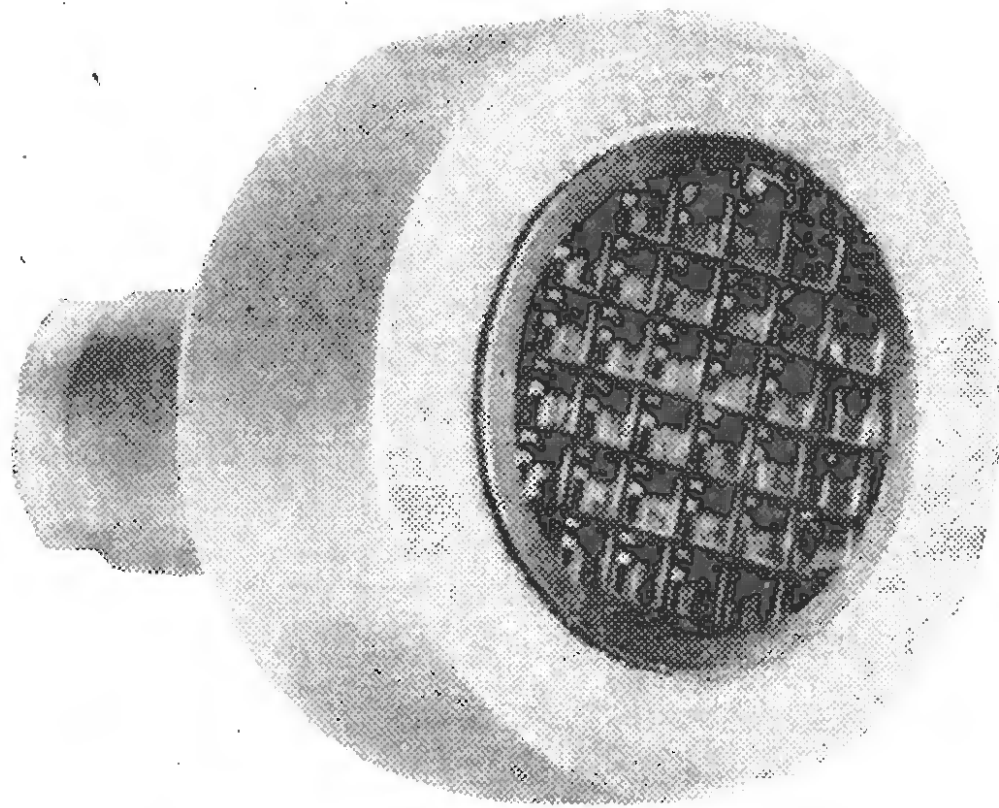

A silicon surface-barrier detector with a detachable collimator (Elliott S.R.D.I.).

photo-electrons at the cathode of a photomultiplier tube is very inefficient.

For any specific material the fraction of the total energy used in ion formation is almost independent of the initial energy of the radiation and of the type of incident particle. Thus a particle of 2 MeV energy will produce about twice as many ions as a 1 MeV particle absorbed in the same medium, but the ions formed by the 2 MeV particle will be distributed over a greater path length. In many types of detector the number of ions collected (and therefore the output pulse amplitude) is proportional to the energy absorbed from the particle. The energy required to form each ion pair in a gas varies from about 22 to 37 eV according to the nature of the gas.

The ionization produced by a charged particle is a result of the electrostatic forces between the particle and the electrons of the matter through which it is passing. The energy of γ -radiation is dissipated indirectly in three main ways. In the photoelectric effect the whole of the energy of a γ -photon is used to eject an electron from an atom; the fast electron then behaves as a β -particle and produces ions. In Compton scattering the

Resolution of detectors

If a detector is being used for energy spectrometry, the output pulses will not have exactly the same amplitude even if the energy absorbed by the detector from each particle is identical. One reason for this is that the presence of noise pulses may increase or decrease the amplitude of the detector output pulses. In addition, the exact fraction of the energy of the incident particle used to create ions is determined by probability. A similar effect occurs in scintillation counters where the exact fraction of the energy used to create photons (and hence electrons at the photo-multiplier cathode) shows a statistical variation around an average value. Thus if the output pulse amplitude of any detection system is converted into an energy spectrum by means of a pulse height analyser, the spectrum for monoenergetic particles will be of the form shown in Fig. 1. In a spectrum of radiation containing a number of peaks, two of the peaks may be so close together that they cannot be distinguished from a single peak. The width of a single peak at half the

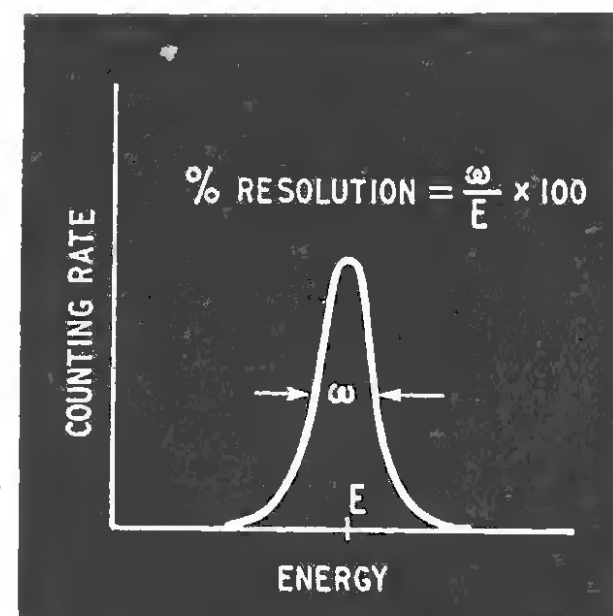

Fig. 1. A typical energy spectrum of monoenergetic radiation.

maximum height may be used as a measure of the energy resolution of the system.

SEMICONDUCTOR DETECTORS

In order that the statistical spread of each energy peak shall be as small as possible, the material of the detector should be chosen so that as many ions as possible are formed for each MeV of energy absorbed from incident radiation. Not only will this reduce the statistical spread in the number of ions formed, but it will also increase the signal amplitude and therefore reduce the effect of any noise pulses.

Each ion pair formed in a semiconductor material requires an energy of about 2-4 eV; this is only about one tenth of that required by gaseous absorbers. It is also very much smaller than the energy required to produce one photoelectron in a scintillation counter (which varies from about 200 eV in a thallium-activated sodium iodide crystal to over 1 keV in organic phosphors). Semiconductor detectors can therefore show excellent energy resolution.

If the maximum resolution is limited by the noise level, it might be expected that semiconductor detectors would show an improvement of about ten times when compared with gas filled detectors. If, however, the statistical spread in the fraction of the energy which is used to create ions is limiting the resolution obtainable, it would be expected that the use of a semiconductor detector would improve the resolution by a factor of $\sqrt{10}$. In practice noise often limits the resolution, but other factors must be taken into account, particularly the noise introduced by the first stage of the amplifier used.

The number of ions formed in a semiconductor material per MeV of absorbed energy is inversely proportional to the gap in the energy band of the material used. It will be shown, however, that other factors are more important than this in the choice of the semiconductor material.

Homogeneous detectors

Semiconductor detectors may be divided into two main types, the homogeneous detectors and the junction detectors. Homogeneous detectors consist of a piece of semiconductor material sandwiched between two electrodes. They can be used for individual particle counting only if the temperature is very low, but certain types of homogeneous detector can be used for integrated flux measurement at normal temperatures. Junction detectors can be used for counting individual particles both at room and low temperatures, but have the disadvantage that their sensitive volume is severely limited. In order to appreciate how these types of detector have been developed and why they have certain limitations, it is necessary to consider the properties of the semiconductor materials used.

The material to be used in a solid-state ionization chamber designed for counting individual particles must have a fairly low specific conductivity, or statistical fluctuations in the steady current passing between the electrodes (i.e. noise) will provide pulses of the same order of amplitude as the pulses caused by the radiation being detected. As in a gas-filled detector, the number of charge carriers present in unit volume of the material in the absence of radiation must be relatively small, although it is desirable that their mobility shall be large in order to obtain short pulse rise times for fast counting. This requirement seems to indicate that a high-purity semiconductor material with a fairly large energy gap

should be chosen so that the number of thermally generated charge carriers will be comparatively small.

A second requirement is that the mean free carrier lifetime should be reasonably high. Impurity atoms, dislocations, etc., in the crystal lattice form local energy bands within the forbidden region. These bands act as traps at which free charges may be temporarily or permanently held, since the probability of recombination with a charge of the opposite sign is fairly small at these trap levels. The trap density should be low (as in a gas-filled detector) or a partial loss of the signals will occur together with a change in the properties of the material as the electron population of the traps is altered ("polarization"). The energy resolution will then be impaired.

It is most unfortunate that materials which have the required energy band gaps have carrier lifetimes which are too low. The energy gaps of germanium and silicon are not large enough to enable a homogeneous block of either of these materials to be used as a detector at room temperature, although the trap density is low. Gallium arsenide has a suitable energy gap, but the carrier lifetimes in this material are too low; in addition it can show oscillations at high field strengths. Diamond was one of the first materials used in a solid-state detector, but apart from the prohibitive price of large crystals of this material, it has a number of other disadvantages including high trap density. Considerable effort is being made to find new materials which will be suitable for homogeneous detectors, but even if such materials are found, it is likely that there will be considerable difficulties attached to the fabrication of single crystals of the materials of the required uniformity.

Flux measuring detectors.—Integrating instruments do not provide a separate pulse as each particle strikes the detector, but are merely used to give an indication of the particle flux at the detector. In this type of instrument traps which lengthen the response time may not matter, since it is only necessary to measure the mean current passing through the detector.

Semiconductor flux detectors take the form of a crystal of the semiconductor material between two electrodes. As the radiation flux (often gamma) increases, the resistance of the crystal decreases. Cadmium sulphide is commonly used in flux detectors, but other group II-VI compounds can be used, such as cadmium selenide and telluride. Sometimes insulators (polythene, p.t.f.e. etc.) are used for dosimetry, since they have a density of approximately unity; however, they are not as sensitive as cadmium sulphide.

Charge amplification.—Cadmium sulphide and selenide are materials of large energy gaps and high trap densities. However, the traps may be used to obtain a charge amplification of perhaps 10,000. If ions are formed by a particle of nuclear radiation striking a cadmium sulphide crystal, the electrons are quickly swept to the anode, but many of the holes are trapped. If suitable electrodes are employed, the field due to the trapped holes will cause electrons to enter the crystal from the cathode. A small proportion of these electrons will neutralise trapped holes, but most of them will pass to the anode. Further electrons will be injected from the cathode until eventually all of the trapped holes will be neutralized.

If the time for an electron to pass across the crystal is t_p and τ is the mean lifetime of an electron, the total charge which passes through the crystal per incident particle will be $n\tau/t_p$ where n is the charge formed by an incident particle. The ratio τ/t_p may be called the amplification of the device. A high gain will be obtained

if τ is fairly large and if t_p is kept small by choosing a thin crystal with a high electron mobility. In practice the electron lifetimes are modified by crystal imperfections which act as electron traps. A high concentration of such traps will reduce the sensitivity and increase the response time. The crystals are fine needles about 1 cm long with indium electrodes attached to them. They are sealed in a glass tube. The most suitable crystals must be selected from a batch which have been grown from the vapour phase.

Cadmium sulphide and selenide detectors are available with sensitivities of 0.1 to 50 $\mu\text{A rad}^{-1}\text{hr}^{-1}$; generally the cadmium sulphide types are the more sensitive. A linear response over many orders of magnitude up to at least 10^8 rad hr^{-1} can be obtained. These detectors have the advantages that they are small and cheap (less than £5) and the associated instrumentation could hardly be simpler. It is only necessary to connect a cadmium sulphide detector in series with a moving coil microammeter and a battery to make an inexpensive portable γ -ray monitor. These detectors are not damaged by high radiation intensities.

One of the main disadvantages of the cadmium sulphide detector is the long response time for moderate radiation intensities (~ 1 sec.). When a cadmium sulphide detector is placed in a radiation field of moderate intensity, the current passing increases fairly slowly to a maximum value in a time which is of the same order as the lifetime of the trapped carriers. A similar slow decrease occurs when the detector is removed from the field. The response time is short at high intensities (where the traps are quickly filled), but it is generally so large at intensities of the order of the recommended human tolerance levels that it seems doubtful whether these detectors in their present form will be useful for health monitoring at low intensities.

The response time of a cadmium sulphide cell which has been kept away from radiation for some time is greater than that of a cell which has been irradiated during the previous few hours. In order to avoid this effect, some cadmium sulphide cells incorporate a radioisotope in the semiconductor material so that some of the deeper traps are kept filled. Such crystals pass a small current even in the absence of an external field and this current must be "backed off" in the instrument.

It has been found that cadmium sulphide detectors giving current gain can produce single pulses of several volts amplitude when they absorb α -particles⁽²⁾. Although the energy resolution and maximum counting rate are very limited, such low cost α -counting systems may be useful when a large number of the detectors are required.

Junction detectors

In a p-n junction holes from the p-type semiconductor initially diffuse across the junction into the n-type and electrons from the n-type diffuse into the p-type. Equilibrium is established when the potential developed across the junction by this carrier diffusion prevents further diffusion from taking place. The junction potential repels free charges away from the junction. The junction region contains no free charge carriers and is therefore referred to as the depletion region. The application of a negative bias potential to the p-type material will increase the depth of the depletion layer (and hence decrease the junction capacitance) by drawing mobile charges further from the junction.

Although the number of free charge carriers in a homogeneous sample of silicon is too great for it to be employed as a solid-state ionisation chamber at room temperature,

silicon p-n junctions can be made in which the depletion region is used as the active part of a solid-state detector at room temperature.

Silicon junction detectors are the most commonly used form of semiconductor detector. The depth of the depletion layer is, however, severely limited and is dependent on the applied reverse bias potential. Germanium junction detectors must be cooled to liquid nitrogen temperatures.

Depletion depth.—The depth of the sensitive depletion region of a junction detector is controlled by the applied bias voltage; optimum bias voltages range from a few volts to over a kilovolt. The depletion depth, d , is given by the following approximate equations:—

$$d \approx 5 \sqrt{\rho V} \times 10^{-5} \text{ cm in n-type silicon}$$

$$\text{and } d \approx 3 \sqrt{\rho V} \times 10^{-5} \text{ cm in p-type silicon}$$

where ρ = specific resistance of the silicon used in ohm cm, and V = the applied bias voltage.

The depletion depth required to stop a charged particle depends on the type of particle and its energy. For example, a 5.5 MeV α -particle requires a depletion depth of about 25 μm in silicon for complete absorption, whereas a β -particle of about 56 keV or a proton of about 1.4 MeV will penetrate to a similar depth. A depth of about 0.2 mm of silicon is required to stop a 0.21 MeV electron or a 5 MeV proton; this depth can be obtained by the use of a n-type silicon of resistivity 3.6×10^3 ohm cm at a bias of about 46V.

A germanium depletion region of a certain depth will stop particles of about twice the energy of those just absorbed by a silicon depletion region of the same depth.

The charge collection time, τ , in a thick detector is given by the approximate equation⁽³⁾:—

$$\tau = \frac{W^2}{\mu V}$$

where W is the depletion depth of the detector, μ the carrier mobility, and V the applied bias voltage. As τ is proportional to W^2 , it is desirable to keep W as small as possible consistent with the absorption of the particle. It is also desirable to make W only slightly greater than the particle range if there is an appreciable gamma background. On the other hand, it is desirable that W should be large for very high resolution spectroscopy, since the junction capacitance will then be small.

An excessive bias voltage will result in increased noise owing to the greater current flowing. At small bias voltages inefficient charge collection will also result in increased noise. An increase in the bias voltage will have the advantage that the charge carrier transit time will be reduced. The electric field strength at all points in the semiconductor material must be considerably less than that at which avalanche breakdown occurs in silicon (about $6 \times 10^5 \text{ V cm}^{-1}$). A graphical method for determining the optimum detector operating conditions has been published⁽⁴⁾.

Junction detector construction

Silicon surface barrier junction detectors are made from n-type silicon, a p-type layer being formed at one face by spontaneous oxidation. A gold film of about 20 to 50 $\mu\text{g cm}^{-2}$ is evaporated onto the oxidized face to form one electrode and an aluminium or magnesium alloy electrode is formed by evaporation on the back surface of the silicon. The depletion region extends from the

gold electrode inwards to a depth which depends on the applied bias, but which is normally less than 1 mm. This type of detector is fairly easy to make in the laboratory, but the percentage of really good detectors which will withstand a high bias and produce little noise is not usually very high.

Silicon diffused junction detectors are manufactured by allowing an element such as phosphorus or boron to diffuse into one side of a silicon slab (normally p-type) at a temperature of perhaps 900°C in an inert atmosphere. An aluminium film is simultaneously allowed to diffuse into the slab from the other side. One disadvantage of the diffused junction detector is that the high temperatures employed in its manufacture may lead to a reduction in the carrier lifetimes; surface barrier detectors are not raised above room temperature during manufacture and therefore do not suffer from this effect. Generally the diffused junction types are somewhat more robust and for this reason are likely to be more suitable for some purposes.

Lithium-drifted junction detectors can be made with depletion regions of 1 to 2 cm by employing a principle discovered by Pell⁽⁵⁾. Initially lithium is allowed to diffuse into one face of a silicon slab under very carefully controlled conditions. Lithium is a donor in silicon and the Li⁺ ions rapidly diffuse into interstitial sites in the lattice. They are then caused to drift at a lower temperature under the influence of an electric field. This results in a deep depletion region being formed. The lithium ions tend to pair off with boron impurity atoms present in the silicon so that the specific resistance of the semiconductor material and hence the depletion depth is greatly increased. The amount of drifted lithium automatically adjusts itself to compensate for the presence of the acceptor ions to an accuracy of up to 0.001%. Lithium drifted germanium detectors can be made in a similar way.

Lithium-drifted silicon surface barrier detectors have been prepared with window thicknesses of less than 10⁻⁴ cm and depletion depths of a few mm.

JUNCTION DETECTOR APPLICATIONS

α-counting and spectrometry.—Silicon junction detectors are replacing scintillation counters for many α-monitoring purposes, especially where a probe of small size is required. The low background count of the semiconductor detector enables it to be employed to measure the activity of very weak α-sources; background counting rates of less than 0.15 counts per hour have been reported⁽⁶⁾.

Silicon surface barrier and diffused junction detectors are ideal for α-particle spectrometry. α-particles of normal energies are completely absorbed in the narrow depletion region. The thin window of the detector combined with the small amount of energy required to form an ion pair in silicon enables very high resolution to be obtained. It is necessary to place the specimen and the detector in a vacuum if the best possible energy resolution is required, since α-particles lose an appreciable part of their energy in air.

The high resolution offered by silicon junction detectors in α-spectrometry almost always enables the emitting radioisotope to be identified. Indeed, the element no. 103, lawrencium, was first identified in this way although only a few counts per hour could be recorded. The high energy resolution obtainable with a semiconductor α-spectrometer is well illustrated by the americium-241 spectrum shown in Fig. 2.

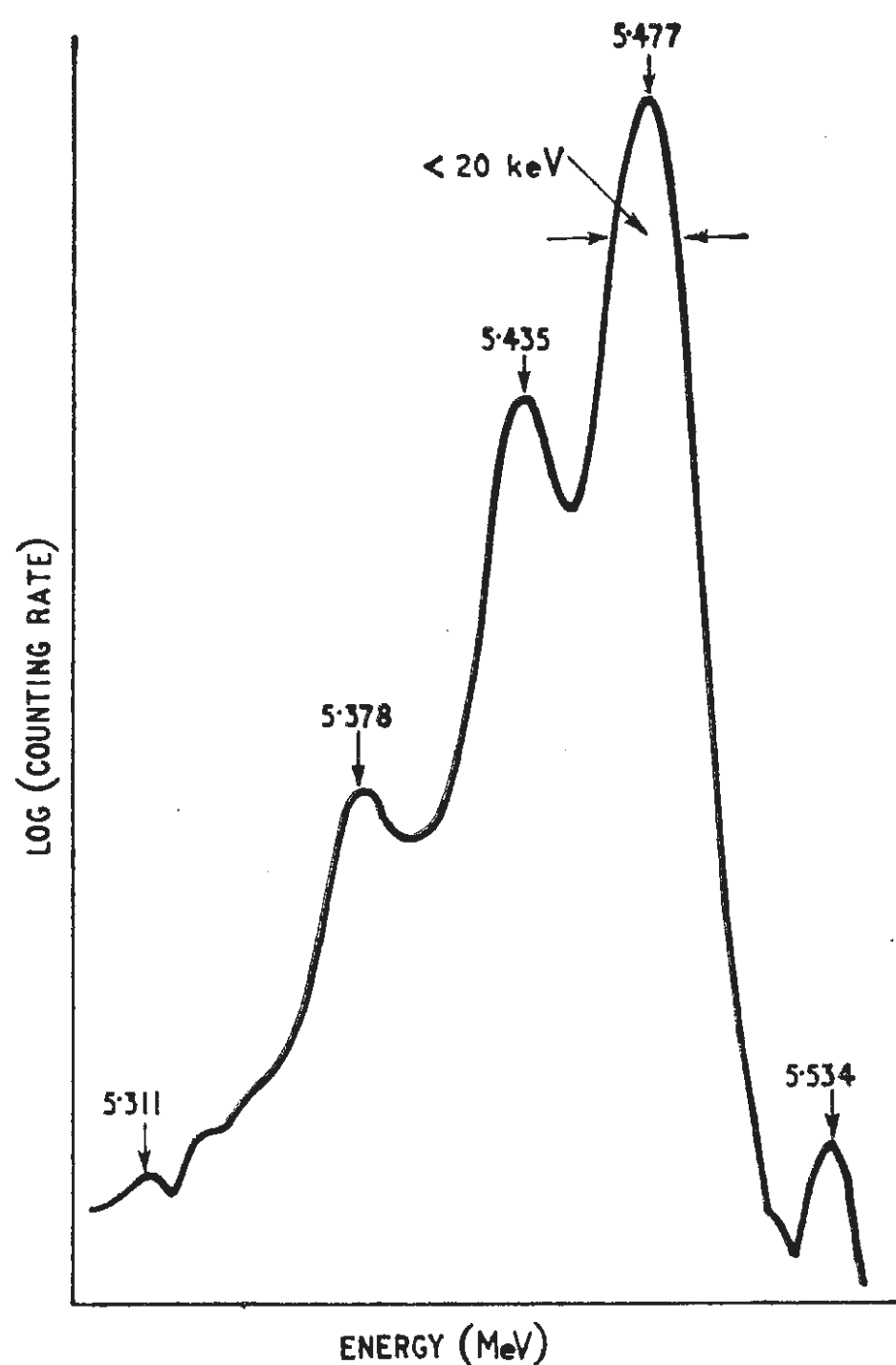

Fig. 2. The α-spectrum of americium 241. The excellent energy resolution is obtained by cooling a detector with a depletion depth of about 1mm.

If air containing α-emitting dust is drawn through a filter paper, the amount of each α-emitter present can be estimated from the energy spectrum of the material on the filter paper; when other types of detector are employed, it may be necessary to wait one or two days for the natural radioactive materials in the air to decay. An automatic α assay equipment which includes a 2 cm dia. solid-state detector has been designed for monitoring the activity of filter papers from the personal air samplers worn by people employed in active areas.

β-counting and spectrometry.—A junction detector can be used for β-counting if the depth of the depletion region is sufficient to absorb enough energy from each particle (10-15 keV) to produce a pulse which exceeds the level of the noise pulses. Semiconductor detectors are not very suitable for the counting of very low-energy β-radiation at room temperature. The small size of the detectors, however, renders them especially attractive for certain medical applications, especially in cancer work.

For β-spectrometry it is necessary that almost all of the particles shall be absorbed within the depletion region. High resistivity detectors should be employed at a fairly high applied bias for β-spectroscopy in order to obtain a suitable depletion depth. Lithium-drifted silicon detectors should normally be used for β-energies exceeding about 500 keV. They can be made with depletion regions deep enough to absorb β-particles with energies up to about 8 MeV and may be used at room temperature or, for better resolution, at liquid nitrogen temperature.

The detectors offer better resolution than scintillation β-detectors but have the disadvantage that they require a low-noise amplifier. Except at low energies a semiconductor detector is very suitable for use in magnetic

β spectrometer instead of a Geiger-Müller or scintillation detector.

γ -counting and spectrometry.—Solid state detectors are not efficient γ -detectors, since their volume is small and the atomic number of the semiconductor material is low. They are much more satisfactory for the counting of fairly low energy γ -rays or of X-rays than high energy γ -rays, since a much greater fraction of the former cause ionization in the crystal. Scintillation detectors employing a thallium-activated sodium iodide crystal are more efficient γ -ray detectors than any semiconductor device available at the present time, since the size of the crystal can be fairly large, its density is high and the iodine (of the sodium iodide) has a high atomic number.

Silicon junction detectors are available for the measurement of γ -radiation dose rate. They are small, rugged and stable devices, the typical sensitivity being 10^6 to 10^8 counts per rad. In medicine lithium-drifted silicon devices are used to measure the doses given in cobalt therapy. Owing to their low γ -efficiency, semiconductor detectors are more useful for measuring medium to moderately high levels of γ -radiation than very low levels.

For γ -spectroscopy lithium-drifted germanium devices offer resolutions exceeding those of other types of detector at energies greater than about 300 keV. At lower γ -ray energies the quartz crystal spectrometer offers greater resolution at smaller efficiencies. Lithium-drifted silicon detectors can be used for low-energy γ - and X-ray spectroscopy (preferably at liquid air temperatures), but germanium (atomic number 32) doped with gallium or zinc has a much greater photoelectric absorption coefficient than silicon (atomic number 14).

Lithium-drifted germanium detectors must not only be used at low temperatures, but they must also be stored at low temperatures. RCA state that their lithium-drifted germanium diodes should be stored at or below -20°C and that storage at liquid nitrogen temperatures should prolong their life indefinitely. Storage at room temperature may cause failure within three months.

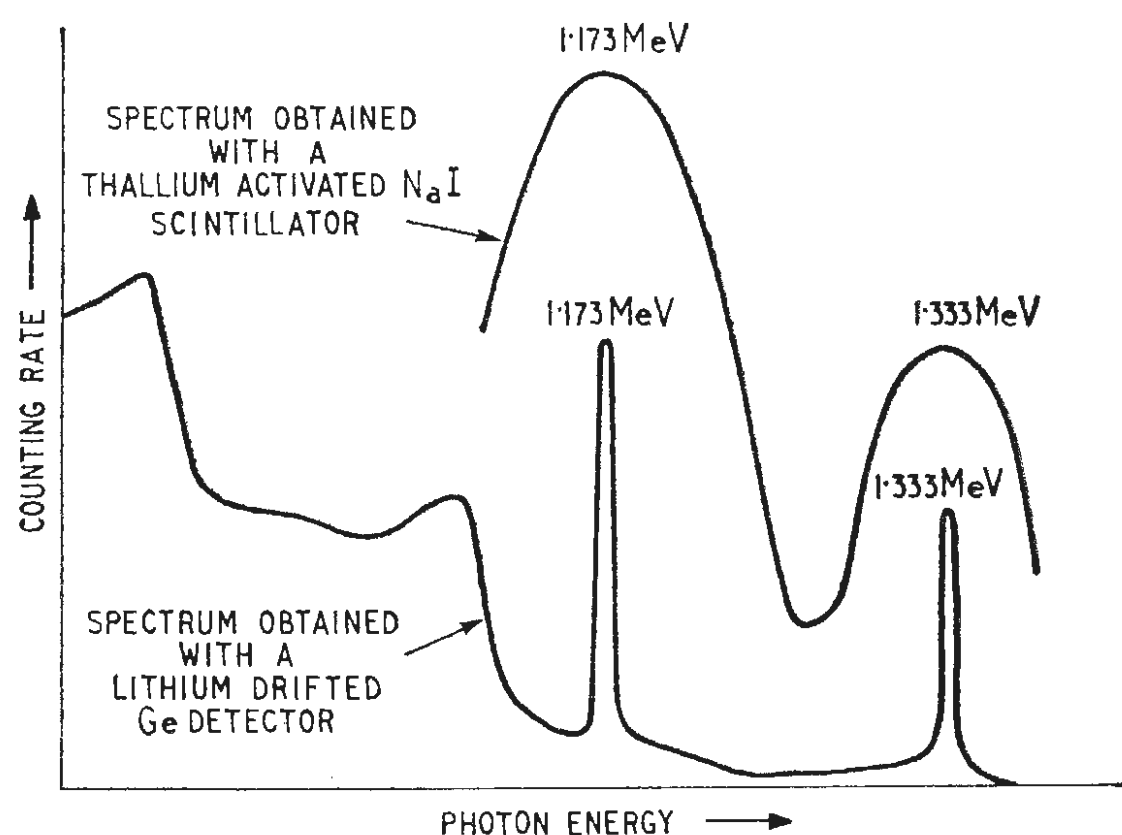

Fig. 3. Cobalt-60 γ -spectra showing resolution of lithium-drifted Ge detector compared with that of a normal spectrometer.

Lithium ions are quite mobile in a germanium lattice at room temperature and the compensated depletion region will be partly lost after the device has been at normal temperatures for a few hours. This is almost unavoidable during shipment, but the compensated region can be regenerated by bolting the device to a heat sink and applying a reverse bias of about 150V in series with a 1 k Ω

current-limiting resistor. The time for which this potential should be applied depends on the length of time for which the device has been at room temperature. After one week at room temperature the reverse current should be passed for about three hours. No reconditioning should be required for detectors which have been stored at temperatures below -40°C .

Lithium-drifted germanium detectors offer very high γ -resolution, since the formation of an ion pair in this material requires an energy absorption of only 2.8 eV and the atomic number is great enough for the probability of absorption by the photoelectric effect to be appreciable. The resolution can be better than 10 keV at energies of up to about 6 MeV. The high resolution of the detector for the two γ -ray energies of cobalt-60 is shown in Fig. 3, together with the type of spectrum obtained from a typical scintillation spectrometer employing a thallium-activated sodium iodide crystal.

Neutron detection.—When neutrons pass through matter they produce very few ions, since with no charge and a high mass they do not react with electrons appreciably. Neutrons are detected by allowing them to react with certain nuclei so that ionising radiation is formed which can then be detected in the usual way.

Fast neutrons are often detected by allowing them to strike protons in a hydrogenous material. The recoiling protons are detected by the ionization they produce. Both thermal and fast neutrons can be detected by allowing them to interact with the nuclei of boron-10, when α -particles are produced, or with lithium-6, when protons are formed. Ionizing particles are also formed when uranium undergoes neutron-initiated fission.

Semiconductor detectors can easily be converted into neutron detectors by placing a thin plastic cap (which contains many hydrogen atoms) or a thin neutron conversion foil containing one of the elements mentioned in the previous paragraph in front of the windows of the detector.

Neutron spectrometers can be made by placing two matched semiconductor detectors on each side of a neutron conversion foil. The total energy of the particles formed when a neutron reacts with the foil is absorbed by the detectors and the incident neutron energy may be calculated from the output pulse size.

Other particles.—Semiconductor detectors can be employed for counting other types of ionizing particles such as protons, deuterons, tritons, fission fragments, etc. If suitable depletion depths are used, the energy spectrum of the particles may be obtained. Generally a lithium-drifted device should be used if a depletion depth exceeding 0.6 mm is required.

SPECIAL TYPES OF DETECTOR

Special types of semiconductor detector are available, but they will not be discussed in detail, since they are likely to be of interest only to the specialist. A fully depleted transmission detector may be used to measure the energy lost by a particle per cm of its path and in combination with a thicker detector provides information which often enables an unknown particle to be identified. Special types of detector are available for work on the polarization (spin) of particles formed in nuclear reactions. Another special detector, the "nuclear triode" provides two coincident output pulses which provide information on the energy of the particle and its position from one end of the detector.

Detectors can be designed which provide internal am-

plification by transistor action⁽⁸⁾, but unfortunately this does not yield an improved signal to noise ratio. If a detector could be designed which would give an amplification similar to the gas amplification of a proportional counter, it would almost certainly have a bright future.

A phosphor has been used in contact with a photodiode⁽⁹⁾. Although this system is much smaller than the conventional scintillation counter, the energy resolution is inferior owing to the noise produced by the photodiode. Nevertheless, the energy required to produce an ion pair is about 70 eV which is less than required for a conventional scintillation counter.

RADIATION DAMAGE

Gas-filled detectors are not permanently damaged by very high radiation levels, but the atoms of semiconductor detectors can be displaced in the lattice by the energy of the radiation and this results in the so-called Frenkel defects⁽¹⁰⁾. The effect of impurity atoms created under neutron bombardment may also affect the detector properties. Lithium-drifted devices are about one hundred times more sensitive to radiation damage than other types of junction detector. The latter are likely to be affected by about 10^{10} α -particles per cm^2 , 10^{15} β -particles per cm^2 , 10^{12} fast neutrons per cm^2 or 10^8 rad of γ -radiation. This limits the application of junction detectors in reactor instrumentation and in the van Allen belts. However, the amount of radiation damage to a semiconductor detector may be estimated from the electrical properties of the device and used as a measure of the integrated radiation dose received.

INSTRUMENTATION

Although a particle of ionizing radiation will produce more ions in a semiconductor material than in a gas filled detector, semiconductor counters lack the gas amplification which occurs in proportional and Geiger-Müller detectors. The output pulses from semiconductor detectors are therefore relatively small and low-noise pre-amplifiers are required.

Let one ion pair be formed in a semiconductor material for each w electron volts of energy absorbed. The charge of an electron is about 1.6×10^{-19} coulomb and therefore the charge collected at each electrode of a detector (assuming no losses) when E MeV of energy are absorbed will be:—

$$Q = \frac{10^6 E}{w} \times 1.6 \times 10^{-19} = \frac{1.6 E}{w} \times 10^{-13} \text{ coulomb} \dots (1)$$

The change in the voltage across the detector, δV , will therefore be given by the equation:—

$$\delta V = \frac{Q}{C} = \frac{1.6 E}{w C} \times 10^{-13} \text{ V} \dots (2)$$

where C is the capacitance of the detector plus stray capacitance. For silicon $w=3.5$ eV and, if C is 50pF, V can be calculated from (2) to be 0.9 mV when a particle of 1 MeV energy is completely absorbed in the depletion region. The pulse rise time can be as small as 10 ns but when the detector is connected to its pre-amplifier, stray capacitance is likely to increase the pulse rise time to about 100 ns. A normal low-noise amplifier of the type used for proportional counting with a gain of 80 to 90 dB may be employed for simple counting.

It can be seen from (2) that the amplitude of the voltage pulse produced by a semiconductor detector is dependent on the capacitance of the device and on the associated stray capacitance. Changes in capacitance will occur

when the voltage across the detector is altered to change the depletion depth, when this voltage drifts slightly or when a change in the cathode temperature of the first valve of the pre-amplifier causes an alteration of the space charge in the valve. Any of these changes will cause a semiconductor particle energy spectrometer to drift during operation if the output voltage from the device is amplified in the normal way.

Equation (1) shows that the charge collected at the electrodes of a semiconductor detector is independent of the capacity of the device. The difficulty mentioned in the previous paragraph can therefore be avoided if a charge-sensitive pre-amplifier is used which produces an output voltage pulse of an amplitude proportional to the charge fed to the input of the amplifier.

The basic circuit of a charge-sensitive pre-amplifier is shown in Fig. 4. Capacitive feedback occurs *via* C_f and the effective input capacitance therefore becomes $C_f(1 + A)$ where A is the loop gain of the system (com-

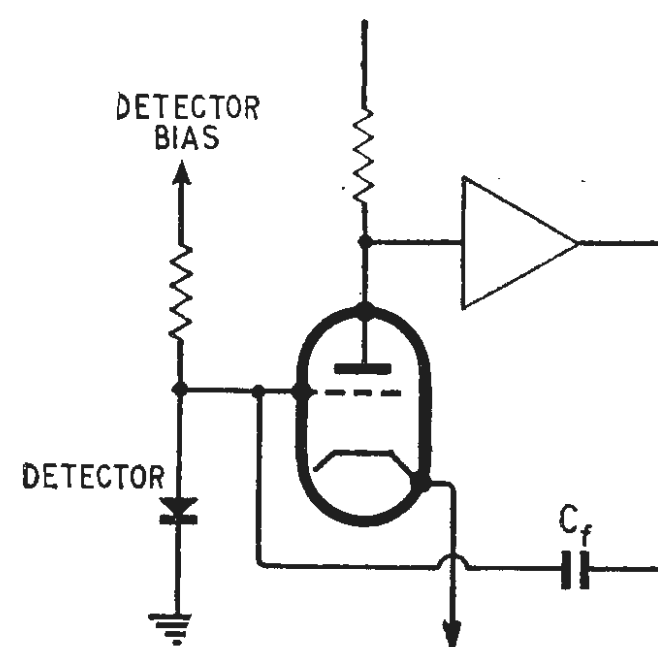

Fig. 4. Basic arrangement of a charge-sensitive pre-amplifier.

pare with the Miller effect in a valve). If A is very large, the output voltage, V_o , is given by the equation:—

$$V_o = \frac{Q}{C_f}$$

Thus the output voltage is independent of the diode and stray input capacitance. The large effective input capacity produced by the feedback renders any change in the diode or stray input capacitance negligible.

Apart from the elimination of drift, the use of a charge-sensitive pre-amplifier for energy spectroscopy enables the effect of variations of the detector bias on the spectrum to be observed without taking into account the change in the detector capacitance. The use of a charge-sensitive preamplifier results in the same signal to noise ratio that would be obtained with a similar voltage-sensitive amplifier. The feedback capacitor, C_f , has a typical value of 5 pF, in which case the output voltage will be about 9 mV per MeV, of absorbed energy.

The complete circuit of an Elliott charge-sensitive pre-amplifier is shown in Fig. 5. A cascode input stage is employed to minimize noise while providing a high gain. The input stage is completely screened and this helps to ensure that feedback occurs only *via* C_f . If square waves of voltage V are injected into the test pulse input, charges of V/C_s (where C_s is the 2.5 pF series capacitor shown) will be injected into the first stage of the amplifier and will produce a peak in the spectrum which is useful for checking the calibration and resolution.

Other designs for charge-sensitive valve pre-amplifiers can be found in ref. 12. Valve amplifiers provide a lower noise than transistor amplifiers⁽¹³⁾ if the detector capacitance is less than about 500 pF, since the grid current

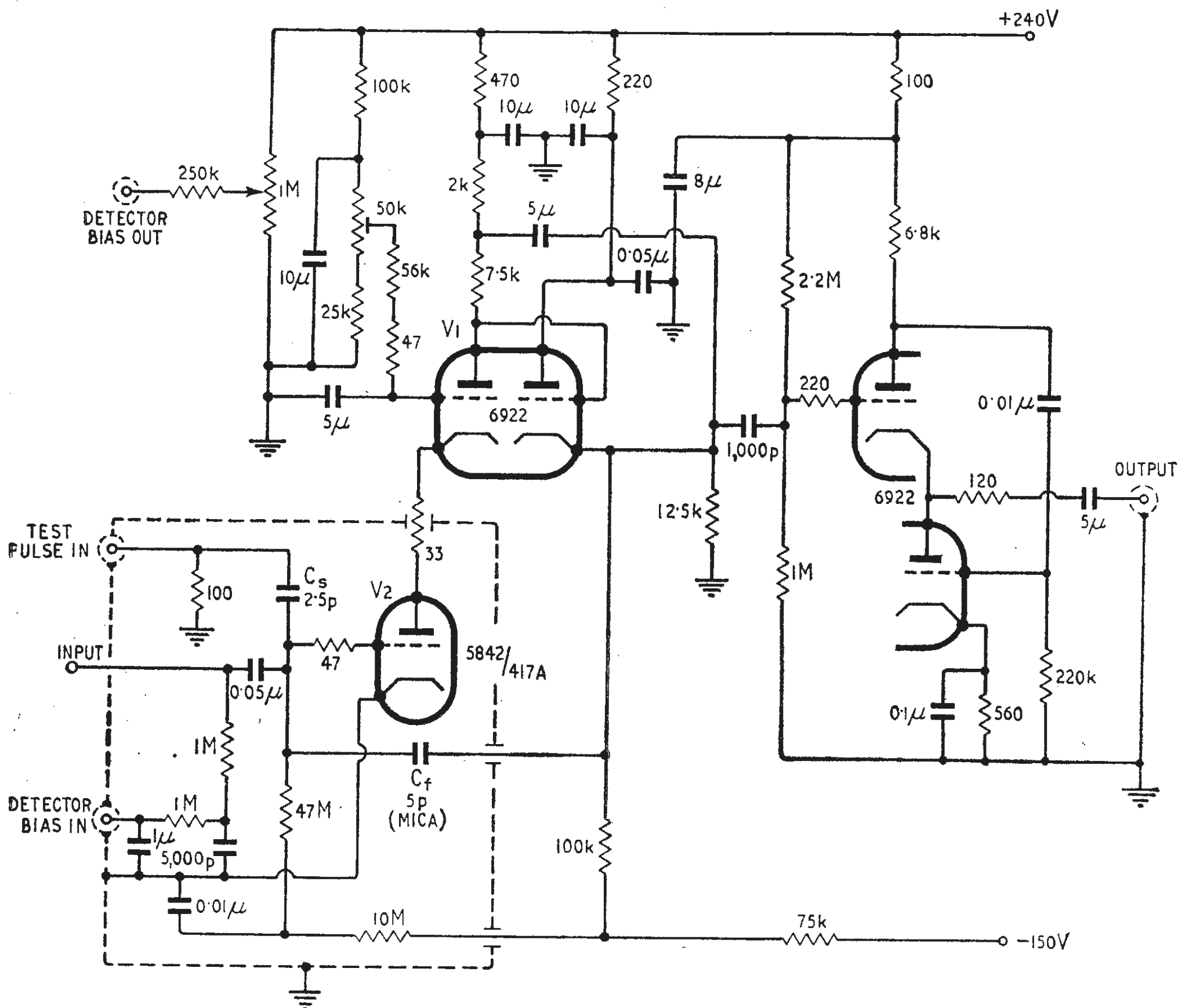

Fig. 5. A charge sensitive pre-amplifier.

of most valves is less than the base current of most transistors.

Due to the large effective input capacitance of charge-sensitive pre-amplifiers they are unsuitable for fast counting, particularly in coincidence work.

Conclusion

Semiconductor detectors have been widely used in nuclear physics laboratories, but are now commonly used elsewhere when small, lightweight and rugged detectors are required which provide a low background counting rate. They can be used for the high resolution spectroscopy of particles which do not have very low absorption coefficients in semiconductors, although they must be cooled for the best results. It seems unlikely that they will completely replace the normal Geiger-Müller tube for simple radiochemical work since they require more complicated instrumentation, and most semiconductor junction detectors are at present more expensive than common Geiger-Müller tubes.

It has only been possible to discuss some of the major points of interest in this survey of semiconductor detectors. Readers requiring further information are referred to ref. 2. Commercially available equipment is surveyed in ref. 13.

Acknowledgements—The writer is indebted to Elliott Bros. Ltd., Mullard Ltd., R.C.A. (Gt. Britain) Ltd., Simtec Ltd. of Canada, 20th Century Electronics Ltd., and to the librarians of A.E.R.E., Harwell for information they have kindly provided.

REFERENCES

1. C. G. Clayton and J. B. Whittaker. "Bulk Photoconductivity Detectors" *Nucleonics*, Vol. 21, No. 4, p.60 (April 1963).
2. G. Dearnaley and D. C. Northrop. "Semiconductor Counters for Nuclear Radiations" (E. & F. N. Spon Ltd., 1963).
3. F. S. Goulding. "Semiconductor Detectors—their Properties and Applications" *Nucleonics*, Vol. 22, No. 5, p.54 (May 1964).
4. J. P. Adams. "Field Strength Relationships for Silicon Surface Barrier Detectors" *Nucleonics*, Vol. 22, p. 112 (August 1964).
5. E. M. Pell. "Ion Drift in an N-P Junction" *J. Appl. Phys.*, Vol. 31, p. 291 (1960).
6. P. G. Salmon and F. L. Allsworth. "Silicon Surface Barrier Radiation Detectors: Some Designs and Applications" A.E.R.E. Harwell, Report R 4122 (1963).
7. A. Ghiorso, T. Sikkelande, A. E. Larsh and R. M. Latimer. "New Element, Lawrencium, At. No. 103." *Phys. Rev. Letters*, Vol. 6, p. 473 (1961).
8. R. L. Williams and P. P. Webb. "Transistor Form of Nuclear Particle Detector" *Trans. I.R.E.*, Vol. NS-8, No.1, p. 35 (1961).
9. N. G. Blamires. "Combination of a Scintillator and a Semiconductor Photo diode for Nuclear Particle Detection." *Nucl. Inst. & Methods*, Vol. 24, p. 441 (1963).
10. G. Dearnaley. "Radiation Damage Effects in Semiconductor Detectors" *Nucleonics*, Vol. 22, p. 78 (July 1964).
11. "315/S.R.D.1/& 1A Radiation Detector." Published by Elliott Bros. Ltd.
12. R. L. Chase, W. A. Higinbotham and G. L. Miller. "Amplifiers for Use with P-N Junction Radiation Detectors" *Trans. I.R.E.*, Vol. NS-8, No. 1, p. 147 (1961).
13. "Commercially Available Semiconductor Detectors and Preamplifiers" *Nucleonics*, Vol. 22, No. 5, p. 63 (May 1964).

NEWS FROM INDUSTRY

Anglo-French Collaboration

WHETHER the Concorde supersonic airliner gets off the ground or not one thing is certain, the collaboration in technical know-how since its inception has improved the bonds between the British and French industrialists, especially in the electronics field. In past months several Anglo-French links have been announced and in recent weeks two more have come to light.

Aircraft Navigational Equipment.—

Ferranti Ltd. and SAGEM (Societe d'Applications Generales d'Electricite et de Mecanique), of Paris, have entered into an agreement whereby the two companies will pool their knowledge and experience in the design and development of aircraft navigation equipment. This agreement has already borne fruit in the award of a contract to Ferranti for an attitude reference system and ground test equipment for the European Satellite Launch Vehicle (Eldo). The gyroscopes and accelerometers for the system will be made by SAGEM. In addition, Sud Aviation (joint constructor with the British Aircraft Corporation of the Concorde), have decided to equip the Concorde with an inertial navigation system developed and manufactured jointly by SAGEM and Ferranti.

Computers. — The two British giants English-Electric-Leo-Marconi Computers and International Computers & Tabulators have put forward a proposal for a joint Anglo-French project for a large computer to the Minister of Technology, Mr. Frank Cousins. A proposal for an identical project has been submitted to the French Government by CITEC (Compagnie pour l'Informatique et les Techniques Electroniques de Contrôle). CITEC is a jointly owned subsidiary company of C.S.F. (Compagnie Generale de Telegraphie sans Fil) and C.G.E. (Compagnie Generale d'Electricite). It was formed last year to develop and produce industrial, scientific and military computers.

The companies concerned have made it clear that without Government support, the proposals will never see the light of day.

Another plan under discussion is the formation of a European consortium including I.C.T. and E.E.L.M. from Britain, CITEC from France, Telefunken from Germany and Ericsson from Sweden.

Plessey Automation Group.—Following the major reorganization of Plessey, which came into effect on 1st July this year, the company's automation group is to be located at Poole in Dorset. The automation group will eventually comprise four divisions covering the principal activities of data handling, data

processing, traffic management and automation accessories. Mr. H. E. C. Nash who joined Plessey as a consultant last January from Elliott-Automation is the group's director.

Bristol to Exeter Microwave Phone Link.—Standard Telephones and Cables Ltd. have received a contract from the Post Office for an extension to the London-West Country radio network being installed by them. The links between London and Bristol and between Bristol and Cardiff are under construction and next year work will begin on the Bristol-Plymouth-Goonhilly leg, of which the new Bristol-Exeter project forms a part. Two r.f. channels will be used (using the aerials already planned) for the extension.

Microwave Associates Ltd., of Luton, have received a contract from the B.B.C. that calls for portable solid state television link equipment operating in the 7 Gc/s band. This equipment is to be used by the B.B.C. for outside broadcast purposes. Either monochrome or colour signals can be transmitted. Microwave Associates have also received contracts from the B.B.C. for point-to-point links and for special ultra light-weight battery operated survey and path test equipment.

Cossor Electronics Ltd. have formed a marine division to market the wide range of marine products manufactured within the Raytheon organization, of which Cossor is a subsidiary. From 1st October, the new division will operate from Shelley House, Noble Street, London, E.C.2. Included in the present range of products are Cossor v.h.f. transceivers, Raytheon 3 and 10 cm radars and Loran navigational equipment. Mr. S. D. Coode-Bate is divisional manager.

H.C.D. Research Ltd. established four years ago to make precision crystal oscillators, frequency standards and associated equipment, recently formed a subsidiary company to handle their growing semiconductor business. The new company, called Semikron Rectifiers and Electronics Ltd., operates from the parent's headquarters at 77 Gloucester Road, Croydon, Surrey (Tel.: THORnton Heath 7485). Last month we made reference to the new company Semikron, but inadvertently transposed the names of the parent and subsidiary. We apologise for any misunderstanding that may have arisen.

Abbey Electronics and Automation Ltd., have, through the acquisition of a new 5,000 sq ft factory, doubled the size of their manufacturing premises at Delamare Road, Cheshunt, Herts. (Tel.: Waltham Cross 25106.)

English Electric's £200,000 computer centre at Huyton, Lancs., was formally opened on 16th July by the Prime Minister, the Rt. Hon. Harold Wilson.

Mullard Applications.—The applications staff of the Mullard Research Laboratories, Redhill, Surrey, have been moved to the company's Central Application Laboratory, New Road, Mitcham, Surrey. (Tel.: Mitcham 3471, Telex 23709.)

Plessey Radar Ltd. are supplying, under a contract worth £40,000, three air traffic control radar installations to the Bulgarian Government. They will be located at Sofia, Varna and Burgas and will provide air surveillance for civil aviation over Bulgaria.

Tektronix U.K. Ltd. have, since the 1st July this year, been operating a repair centre for the maintenance and recalibration of their oscilloscopes and ancillary instruments. Information on this service can be obtained from the field support department, Beaverton House, Harpenden, Herts. (Tel.: Harpenden 61251, Telex 25559.)

The British Radio Corporation, who now market HMV, Marconiphone and Ultra radio and television sets, are moving to 284 Southbury Road, Enfield, Middx. (Tel.: HOWard 2477.) Ultra's former premises at Eastcote, Middx., and the headquarters of the sales division of His Master's Voice and Marconiphone at Cavendish Place, London, W.1, are being vacated.

Texas Instruments have acquired a 6,000 sq ft warehouse and office site at 12 Wellcroft Road, Slough, Bucks. (Tel.: Slough 28578, Telex 84363.) From this address the company's supplies division will operate a same-day service for the supply of small orders for T.I. devices.

C. & N. (Electrical) Ltd., of The Green, Gosport, Hants., offer industry and research an enquiry service in the field of sequential control, data processing and logic circuitry. (Tel.: Gosport 80221, Telex 8621.)

Control Logic of Boston, U.S.A., who manufacture a wide range of digital logic circuit modules, are to have their products marketed in the United Kingdom and Western Europe by Electro Mechanisms Ltd., of 218-221 Bedford Avenue, Slough, Bucks. (Tel.: Slough 27242.)

Mial S.P.A., of Milan, manufacturers of capacitors, have appointed Waycom Ltd., of Capacity House, Rothsay Street, Tower Bridge Road, London, S.E.1, (Tel.: HOP 2615) sole U.K. distributors.

U.K. Solenoid Ltd.—Since the formation of Chilton-Solenoid (U.K.) Ltd. three years ago, there has been some confusion owing to the similarity in name with Chilton Electric Products Ltd., both of Hungerford, Berks. In future, the former company is to trade under the name U.K. Solenoid Ltd.

Pye H.D.T. Ltd.—To form one body within the Pye organization to look after their closed circuit television interests, the industrial division of Pye Telecommunications Ltd. has been combined with the original Pye H.D.T. Company. The initials stand for High Definition Television.

Experimental Thyristor Control Circuits

By N. M. MORRIS,* B.Sc., A.M.I.E.E., A.M.I.E.R.E.

Conclusion of a two-part article presenting a range of thyristor control circuits for use by students and experimenters. The article starts with pulse circuits using unijunction transistors and Shockley diodes then goes on to applications of the control circuits in closed-loop regulators.

UNIUNCTION TRANSISTOR

THE unijunction transistor is a convenient device for pulse generation in thyristor circuits. The device comprises a bar of n-type material with two ohmic contacts and one p-n junction. The two ohmic contacts are known as base-one (B_1) and base-two (B_2) respectively and the p-type material is known as the emitter (E). The circuit employed to produce pulses is shown. While the p-n junction is reverse-biased the voltage across the capacitor rises exponentially, giving a sawtooth waveform at the emitter. When the capacitor voltage reaches a value known as the peak-point voltage, the p-n junction becomes forward-biased and the capacitor discharges through R_1 . This R_1 has a low value, resulting in a pulse output; after the capacitor has discharged the p-n junction returns to a blocking state and it is again possible to charge the capacitor. A pulse of 10 to 20 microseconds duration at an amplitude of about 5 volts is produced and the pulse repetition rate is about $0.8 RC$ seconds. *The actual values depend on the unijunction transistor and components used. Typical values with a 2N1671A (Texas Instruments) unijunction transistor are: V_s , 22 volts; C , $0.1 \mu F$; R , 10 to 100 k Ω ; R_1 , 22 Ω ; R_2 , 100 Ω (required to give temperature stability).

*North Staffordshire College of Technology.

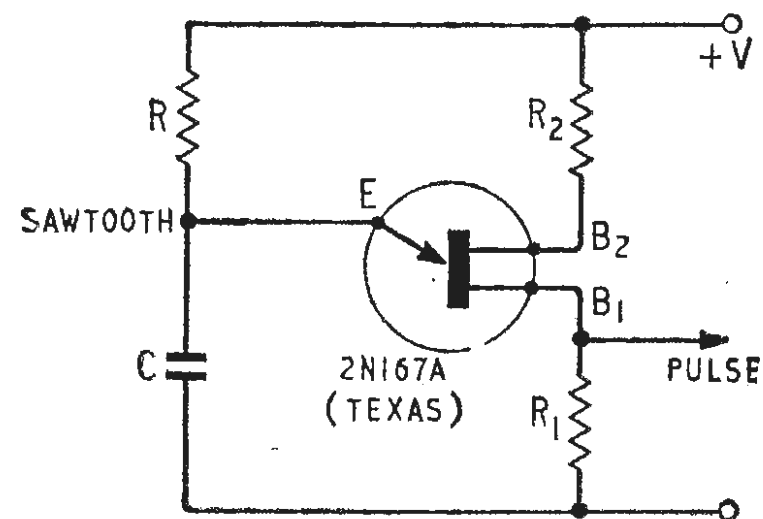

The pulse repetition rate is controlled by the methods outlined for the two-transistor pulse generator circuit above, i.e. by shunt or series control of capacitor charging current. Small modifications to the values of circuit components are necessary, but the principle is unchanged. The output pulse may be connected directly to the gate of the thyristor or through an RC network as shown above. The unijunction circuit may be used directly to replace the two-transistor pulse generator section of the pre-amplifier described last month, p. 399, by connecting the unijunction emitter to the point marked A.

FOUR-LAYER (SHOCKLEY) DIODES

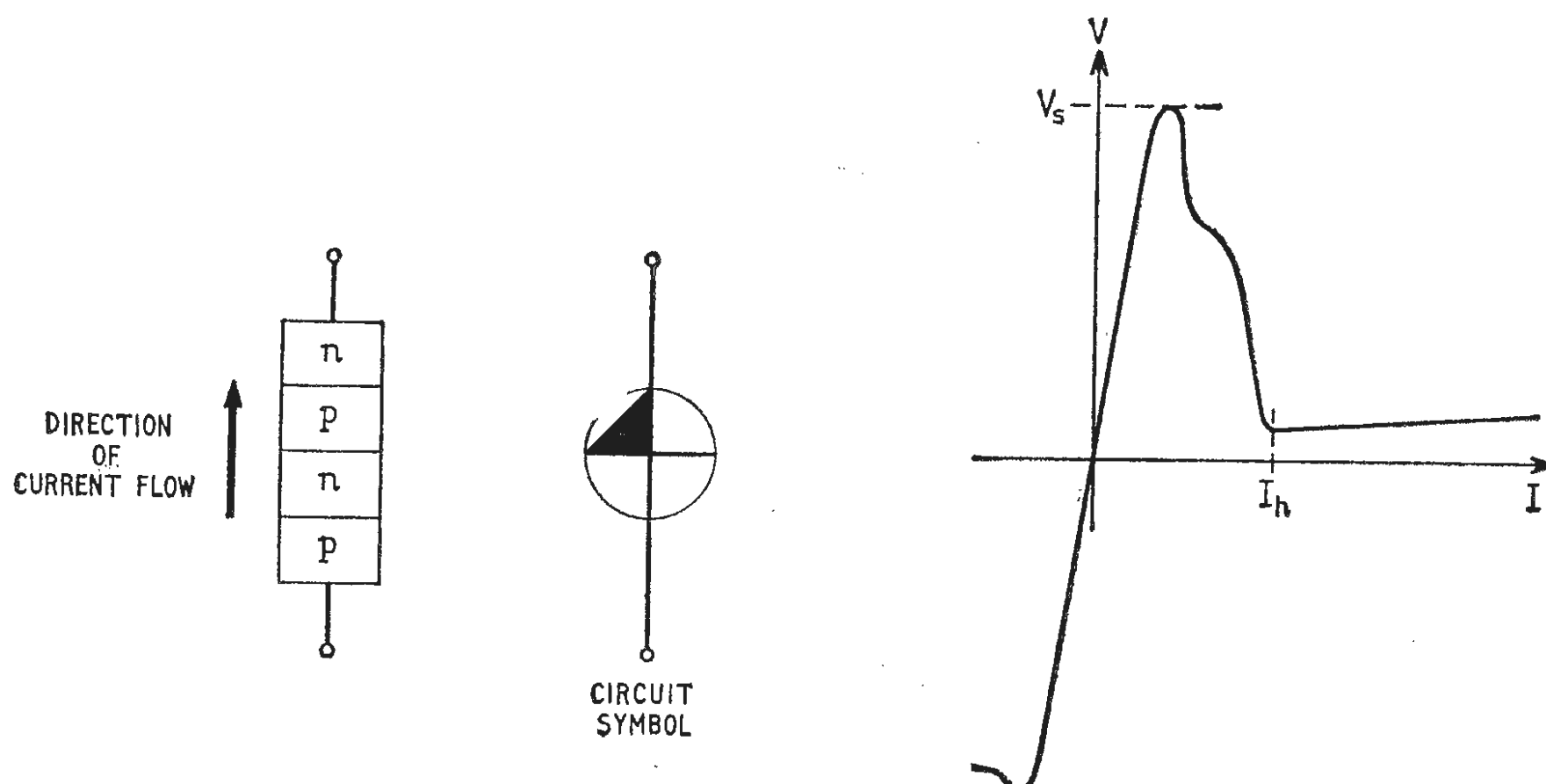

THE Shockley diode is a p-n-p-n device which is triggered from a forward blocking state to a conducting condition when the voltage across it exceeds the switching voltage, shown here as V_s (I_h is holding current). The current at the switching voltage is typically a few hundred microamperes. In the conducting state the dynamic resistance is a few ohms and the device can deliver a peak current of the order of one ampere for about ten microseconds.

GATE CONTROL CIRCUIT USING A SHOCKLEY DIODE

THE gate control circuit shown here is fed from a Zener diode limiting circuit providing a clipped positive voltage of 28 V, which is in excess of diode switching voltage. A suitable diode is the Brush-Clevite Type 4E20-28. The negative voltage applied to the circuit is limited to about 1½ V. If the charging time-constant RC is very

large, the peak voltage across the capacitor in the positive half-cycle may not be sufficient to break down the diode. Relevant voltage waveform for one such value of RC is shown on the left-hand column of waveform diagrams. Reduction of R to about 70 kΩ results in stable firing in the last 10° of each positive half-cycle; waveforms for this condition are shown in the middle column. Further reduction in R results in earlier firing at A (righthand column) giving an increased voltage across the load. At this point the capacitor voltage suddenly falls to a value which cannot sustain the diode holding current and the device reverts to a blocking state. This allows the capacitor voltage to build up again in the positive half-cycle, switching the diode on again at B. By adjustment of R it is possible to control the thyristor conduction over practically the whole of the positive half-cycle.

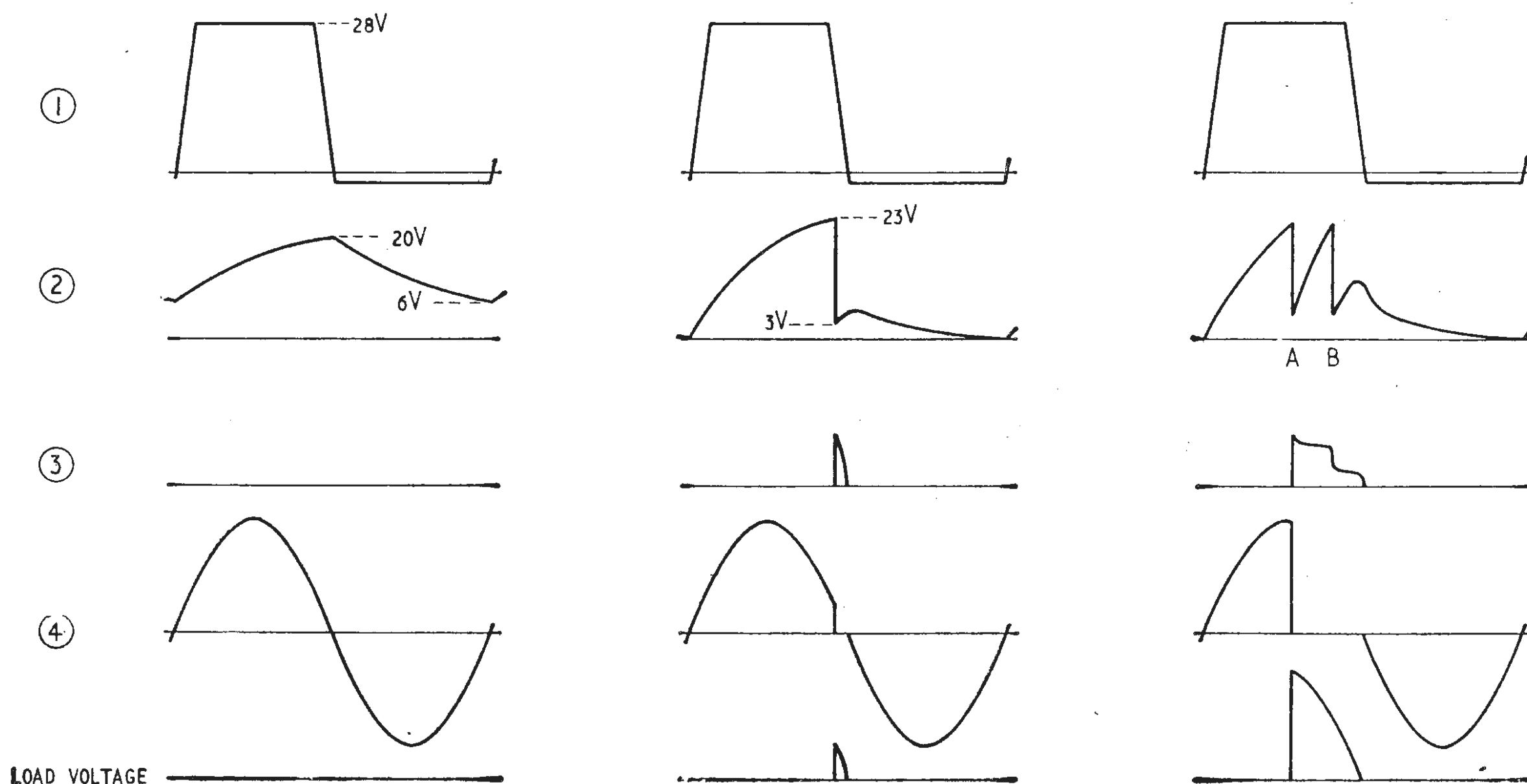
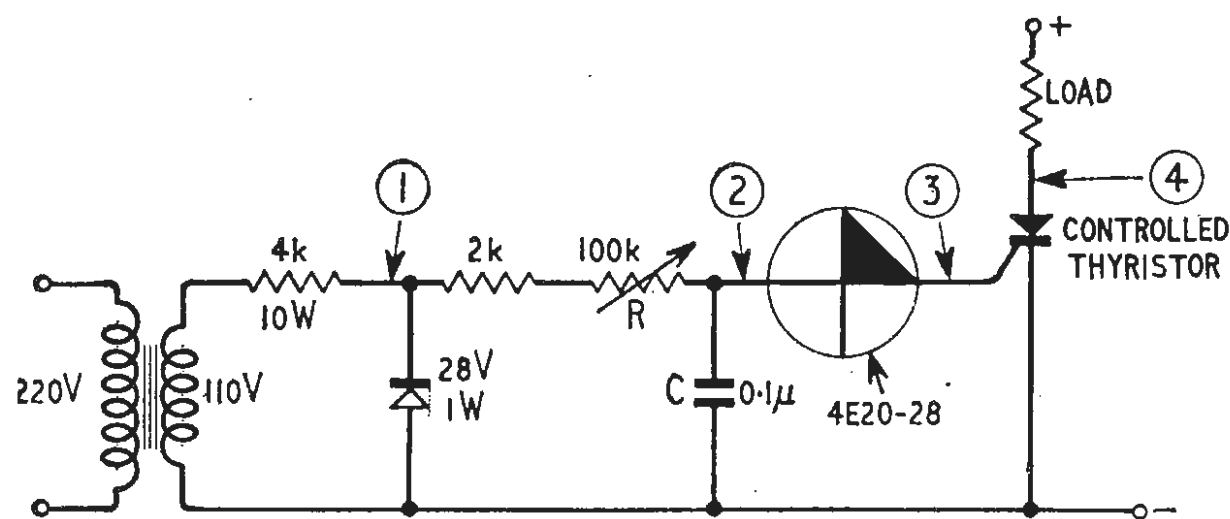

TIME-DELAYED FIRING USING A SHOCKLEY DIODE

THE introduction of a diode between the transformer and the 4 kΩ resistor in the previous gate control circuit allows firing to be delayed. Without the diode in circuit the capacitor can discharge through R and the Zener diode in the negative half-cycle of the supply voltage. With the diode in circuit the leakage resistance is very high and the voltage across the capacitor is retained. If the charging time-constant is large, the thyristor is not switched on in the first positive half-cycle and the potential across the capacitor stays substantially at this value during the negative half-cycle. In succeeding half-cycles the capacitor voltage is "pumped up" until it reaches the switching voltage of the Shockley diode, when the capacitor is discharged and the thyristor is turned on. Reduction of R reduces the time taken to reach the switching voltage, the maximum value of R being set by the condition that the charge and discharge time constants are nearly the same. Waveforms for this mode of operation are shown here.

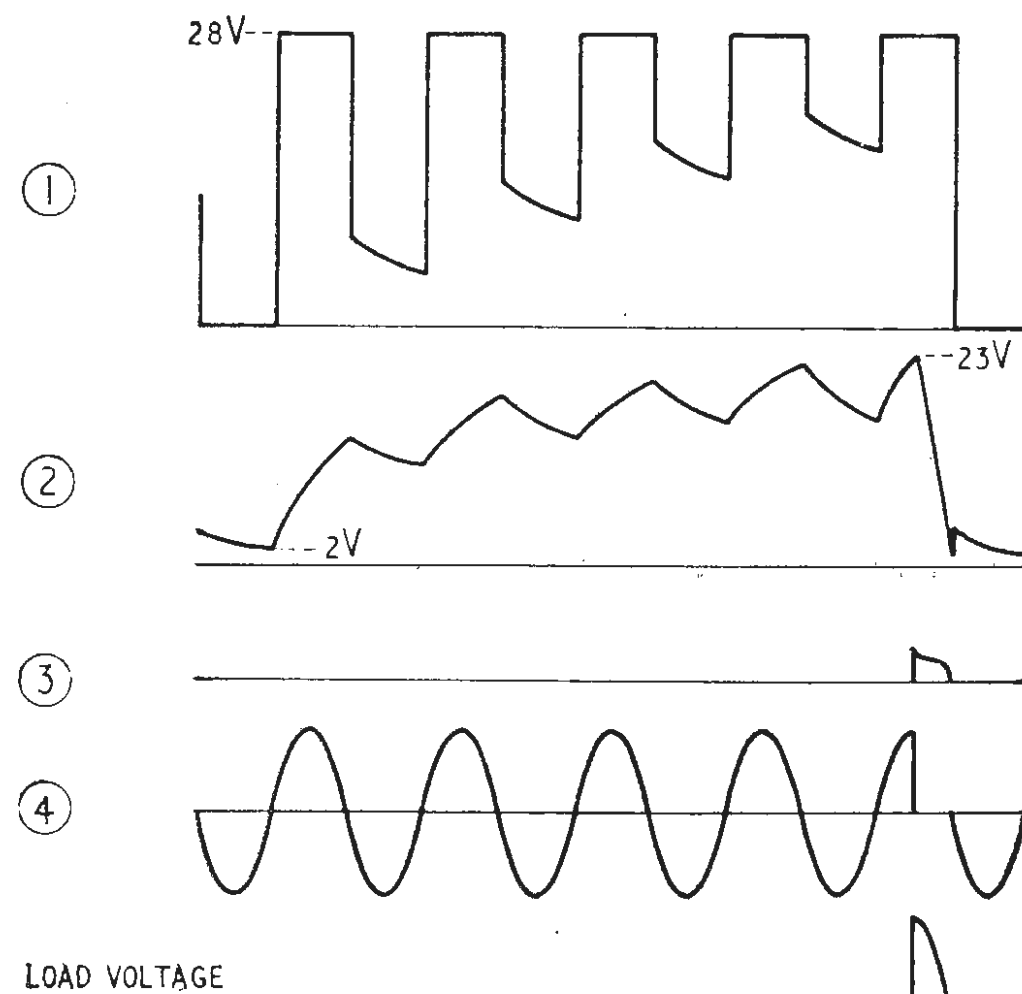

CONTROL OF SHOCKLEY CIRCUIT USING A VOLTAGE INPUT

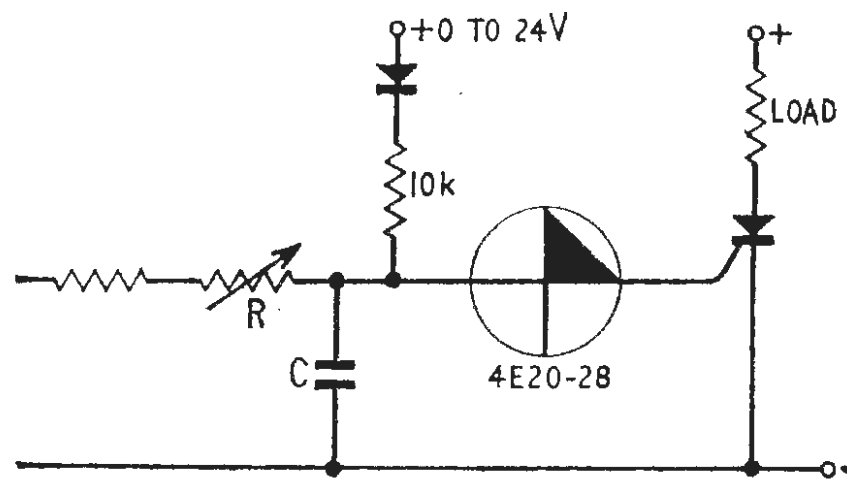

IF the gate control circuit is modified as shown here, the additional potential allows the Shockley diode switching voltage to be reached earlier. Time delayed firing again is obtained by the insertion of a diode in the 110-V supply. Variable resistor R is adjusted to the point where the thyristor just fires. Increasing the externally applied voltage from 0 to 20 V gives full control of firing pulses over the whole positive half-cycle. The external control voltage can conveniently be obtained from the d.c. amplifier given last month (bottom of p. 399).

APPLICATION TO CLOSED-LOOP REGULATORS

THE basic requirements of a closed-loop regulating system are shown at (a). The output, or a signal proportional to it, is compared with a reference voltage and the difference between the two (the error) is amplified to give the output. The higher the gain the lower the error, the limit of gain being set by overall stability, which is dictated by the time lags present in the regulator. A simple voltage regulator is shown at (b). The reference

voltage circuit is given next in this article; the transistor control circuit given on p. 399 last month (pre-amplifier); and the thyristor circuit was given on p. 398 last month ("Full wave power control"). The only time lag of any significance in the system is the RC smoothing network in the voltage signal feedback path. Since there is only one lag involved, the regulator is inherently stable and the amplifier gain may be increased to its maximum value. By feeding back the voltage developed across a low resistor r , as shown in (c), the current in the load resistor R can be maintained constant. For accurate control r should be as small as possible, consistent with the fact that the potential developed across it should be much greater than the allowable error.

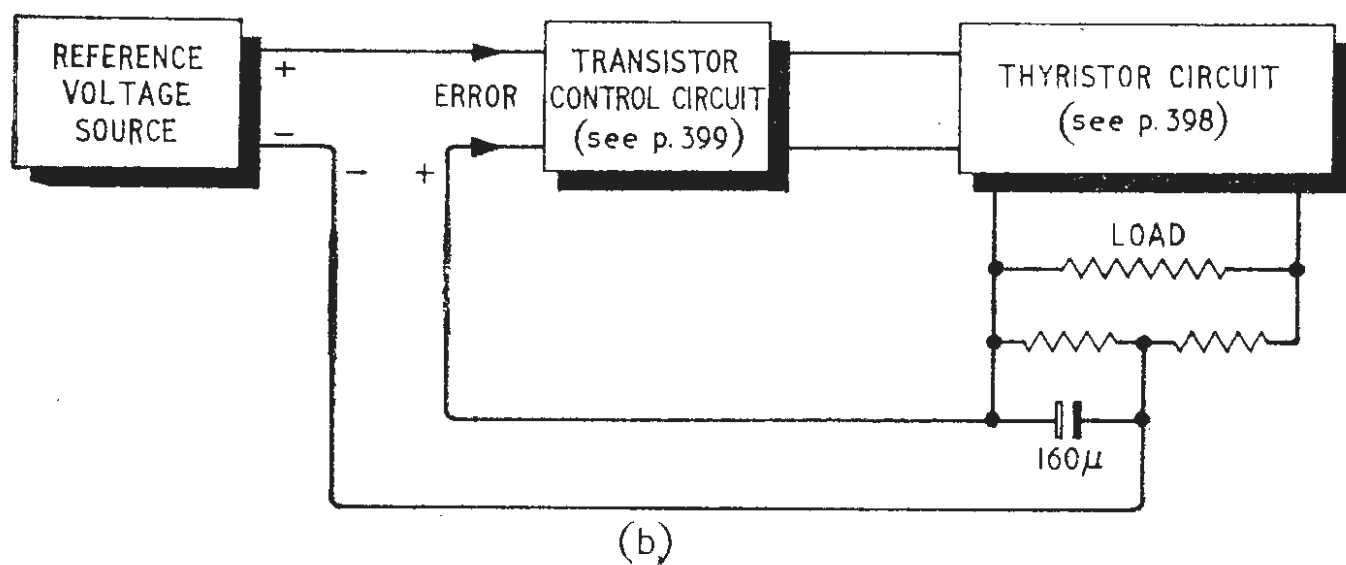
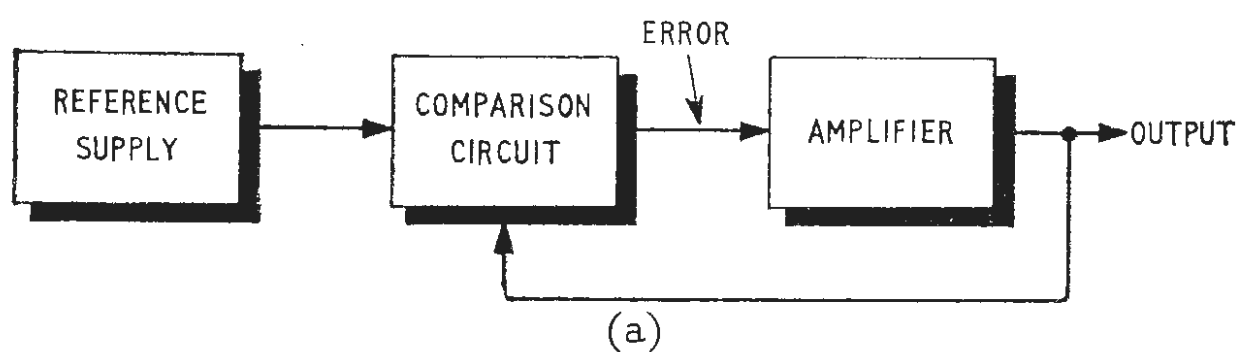

REFERENCE VOLTAGE SOURCE

THE reference voltage source in a closed-loop control system can conveniently be obtained from a single-phase, full-wave rectifier with capacitor smoothing, followed by a Zener diode to stabilize the voltage across the reference potentiometer. If the output of the accompanying circuit is connected directly to the input of the pre-amplifier above the 5 kΩ resistor must be connected into the circuit to limit the maximum excursion of the reference voltage. When it is used in a feedback regulator circuit to be described later the 5 kΩ resistor is short-circuited.

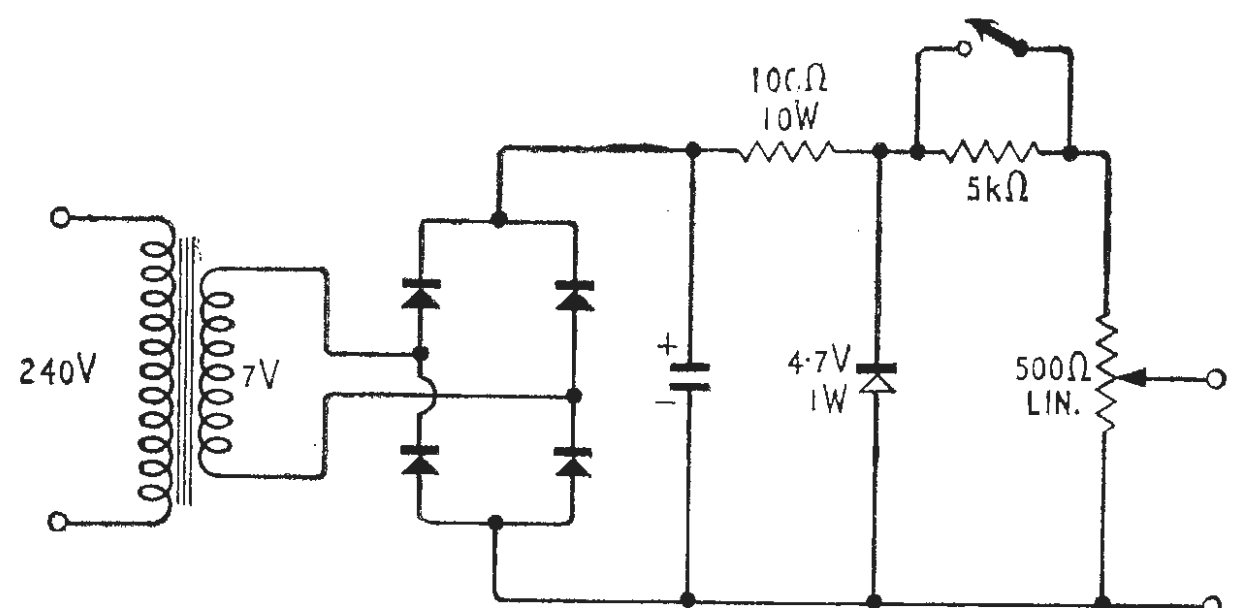

CURRENT LIMITATION IN THYRISTOR CIRCUITS

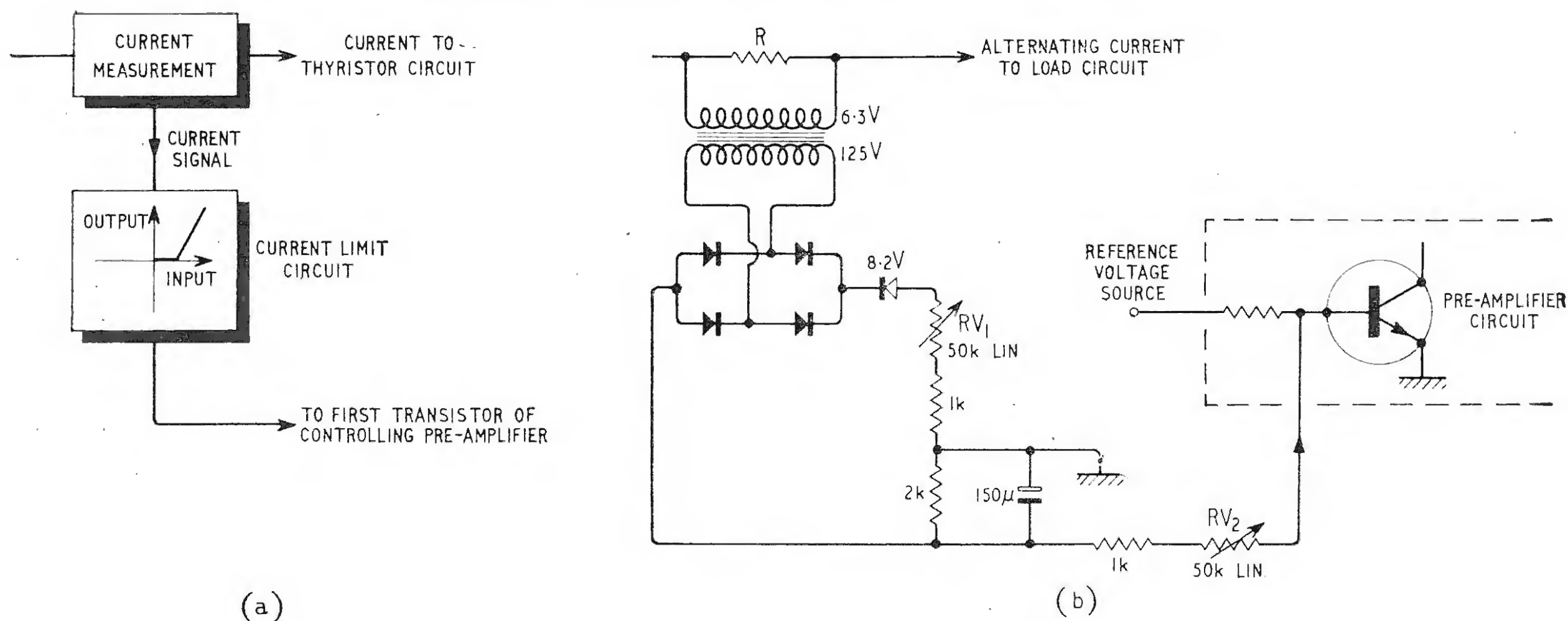

IN order to keep the average dissipation in the thyristor within specified values, even in experimental circuits, it is desirable to provide some method of current limitation. The basic principles are shown here at (a). The current is measured and a signal proportional to it is fed into a circuit which gives zero output for a given range of input signals; beyond this point the output increases with input. The knee of the characteristic is arranged to coincide with the current limit setting. The output of this circuit is applied as negative feedback to input of the controlling pre-amplifier (p. 399 last month), so reducing the overall gain of the regulator. This has the effect of reducing the pulse

repetition rate to the thyristor; hence the load current falls to the required value. It is generally convenient to measure the load current on the a.c. side of the supply by inserting a resistor in series with the load current (b). The r.m.s. voltage across this resistor, R, should be about $1\frac{1}{2}$ V at the value of current to be limited. A heater transformer has been found suitable for this application, the non-linear characteristic being obtained by the Zener diode—resistance network. For minimum current limiting effect RV₁ and RV₂ should be set at their maximum values. If they are reduced to zero the current in the thyristor circuit is limited to a very low value.

CONSTRUCTION OF EXPERIMENTAL CIRCUITS

THE circuits outlined in this article have been used by the author in conjunction with thyristors with ratings between 4 A, 25 p.i.v. and 10 A, 400 p.i.v. Many other methods of control are available including electromagnetic methods, blocking oscillators and Schmitt circuits, and references to the design of these are given on page 454.^{(2) (3) (4)}

For convenience of storage and interconnection of circuits, printed circuit boards were used. A selection of these is shown in the photographs. No. 1 (left) is the two-transistor pulse generator; No. 4 (second from left) is the Shockley diode; No. 5 (third from left) is the unijunction transistor circuit; and No. 6 is a circuit comprising the first two sections of the controlling pre-amplifier. The transistor and Unijunction transistor pulse generator circuits were built up using boards with valve bases on

them for convenience of removal of transistors for other experiments. One transistor is shown removed from its holder.

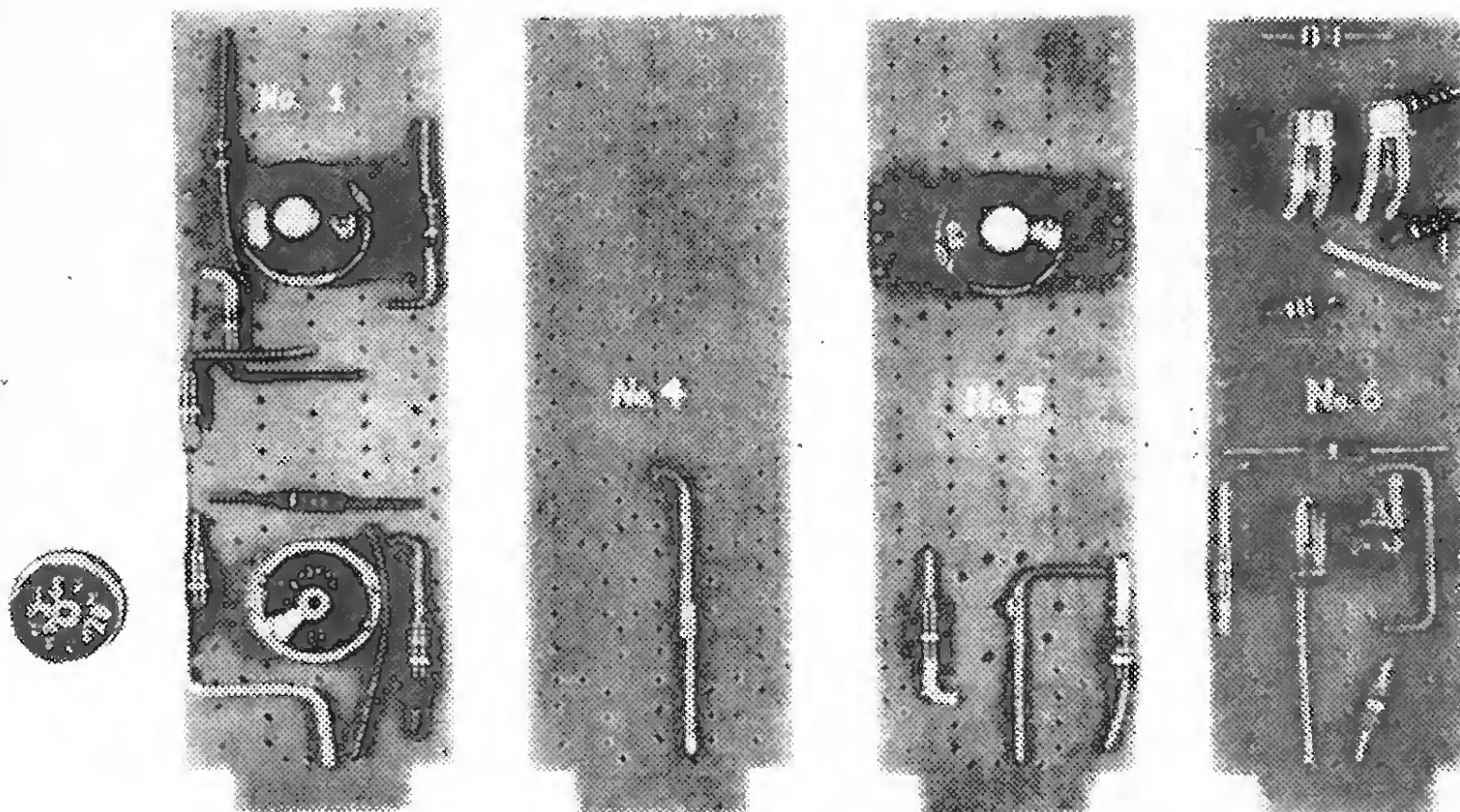

THYRISTORS IN DIRECT CURRENT CIRCUITS

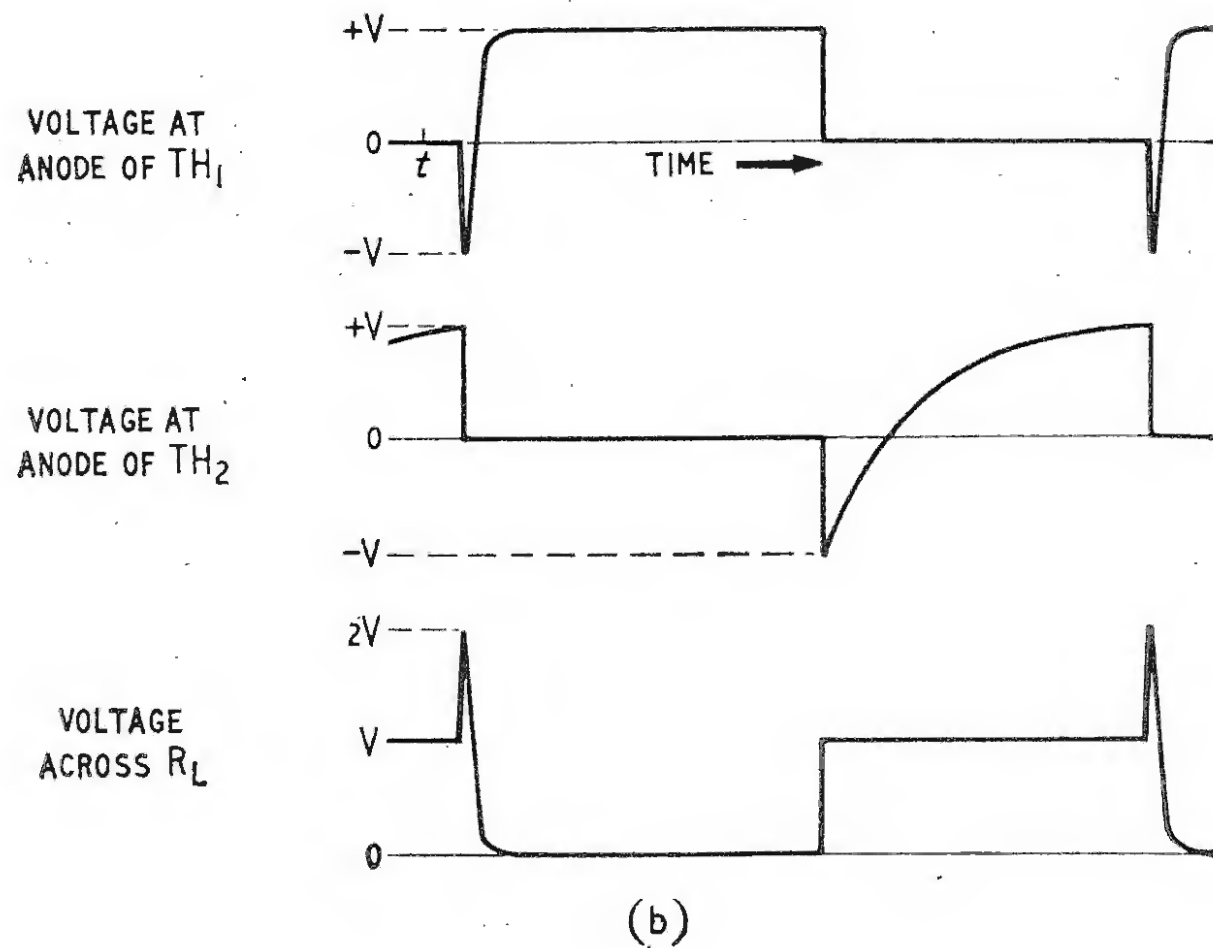
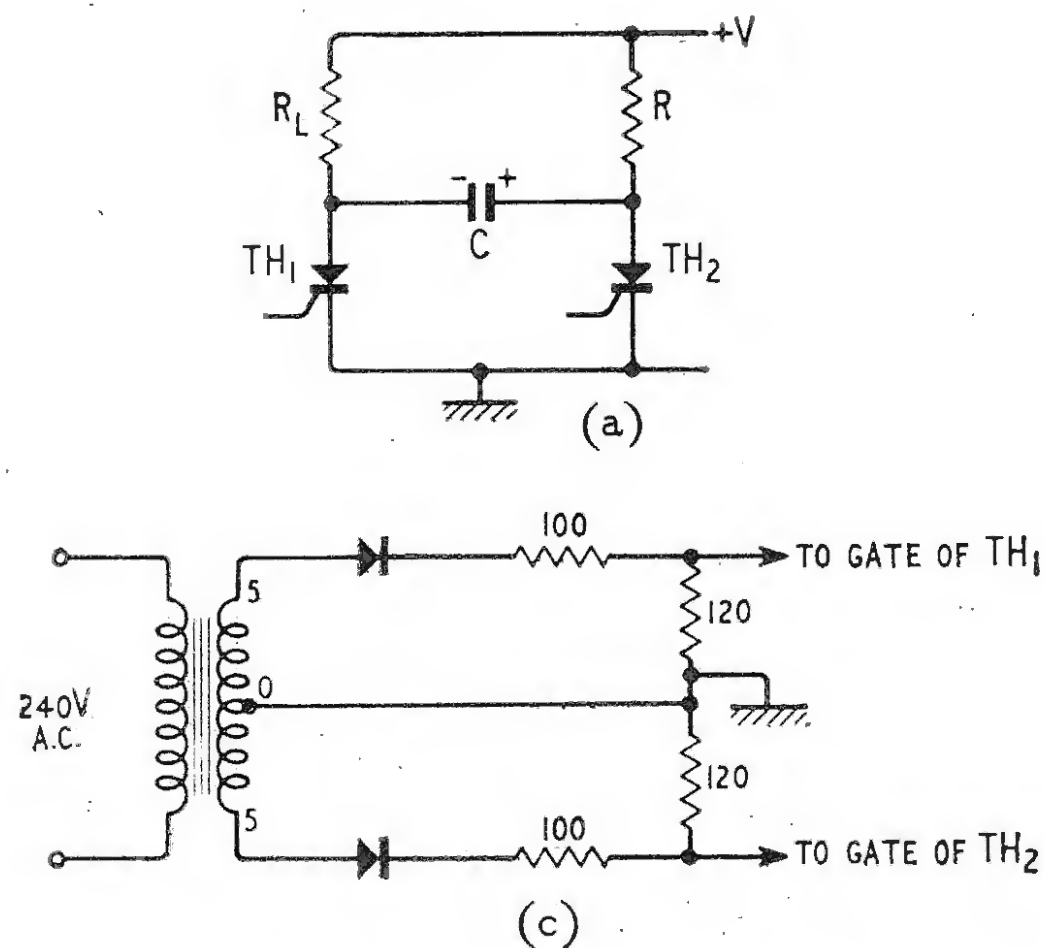

TO switch off a direct current it is necessary to reduce the thyristor current to a value below its holding value so that it can assume its blocking state. Various methods have been devised to do this, most of them involving charging or discharging a capacitor, since it may be regarded as a load or source of practically zero resistance at the time of switching. One simple circuit is shown here at (a).

Suppose TH_1 is conducting at time t as shown in (b). The polarity of the potential across the capacitor is shown in (a); if TH_2 is switched on a little later, the positive terminal of the capacitor is connected to earth, making the anode of TH_1 instantaneously $-V$ volts relative to earth. This thyristor is now reverse biased, and provided forward current does not flow for a time equal to the turn-off time of the device (typically $25 \mu s$), the thyristor will assume its forward blocking condition. With most commercially available thyristors this condition can be satisfied if the product $R_L C$ is greater than 30, where C is in microfarads. To switch the load current on, a signal is applied to the gate of TH_1 which turns TH_2 off by the process outlined above. Resistance R does not have any effect on the switch-off of load current, but the minimum time between switching operations is set by the time taken for the capacitor to charge up to V volts. Resistance R can be selected on the basis that the minimum time between switching operations should be greater than $5RC$ seconds, where C is in farads. In diagram (a), $V=30$ volts, $R_L=15\Omega$, $R=660\Omega$, $C=3 \mu F$. In practical cases the load usually has some inductance and it is necessary to shunt R_L with a diode to allow the load current to decay slowly when the thyristor is turned off.

To allow inspection of the switching waveforms on a c.r.o. the two thyristors must be switched alternately. A simple circuit to perform this operation is shown at (c).

REFERENCES

1. "Firing Requirements for Silicon Controlled Rectifiers," by T. J. Jarratt. *Mullard Technical Communications*, Vol. 6, No. 55, March 1962.

2. "Transistorized SCR Firing Circuits," by T. J. Jarratt. *Mullard Technical Communications*, Vol. 7, No. 65, June 1963.
3. "Simple Electromagnetic Methods of Pulse Generation," by R. F. Burbridge and M. James. *Proc. I.E.E.*, Vol. 112, No. 2, February 1965.
4. "Silicon Controlled Rectifier Manual." General Electric Co. of New York.
5. "Controlled Rectifiers in Stabilized Power Supplies," by F. Butler. *Wireless World*, October 1963.

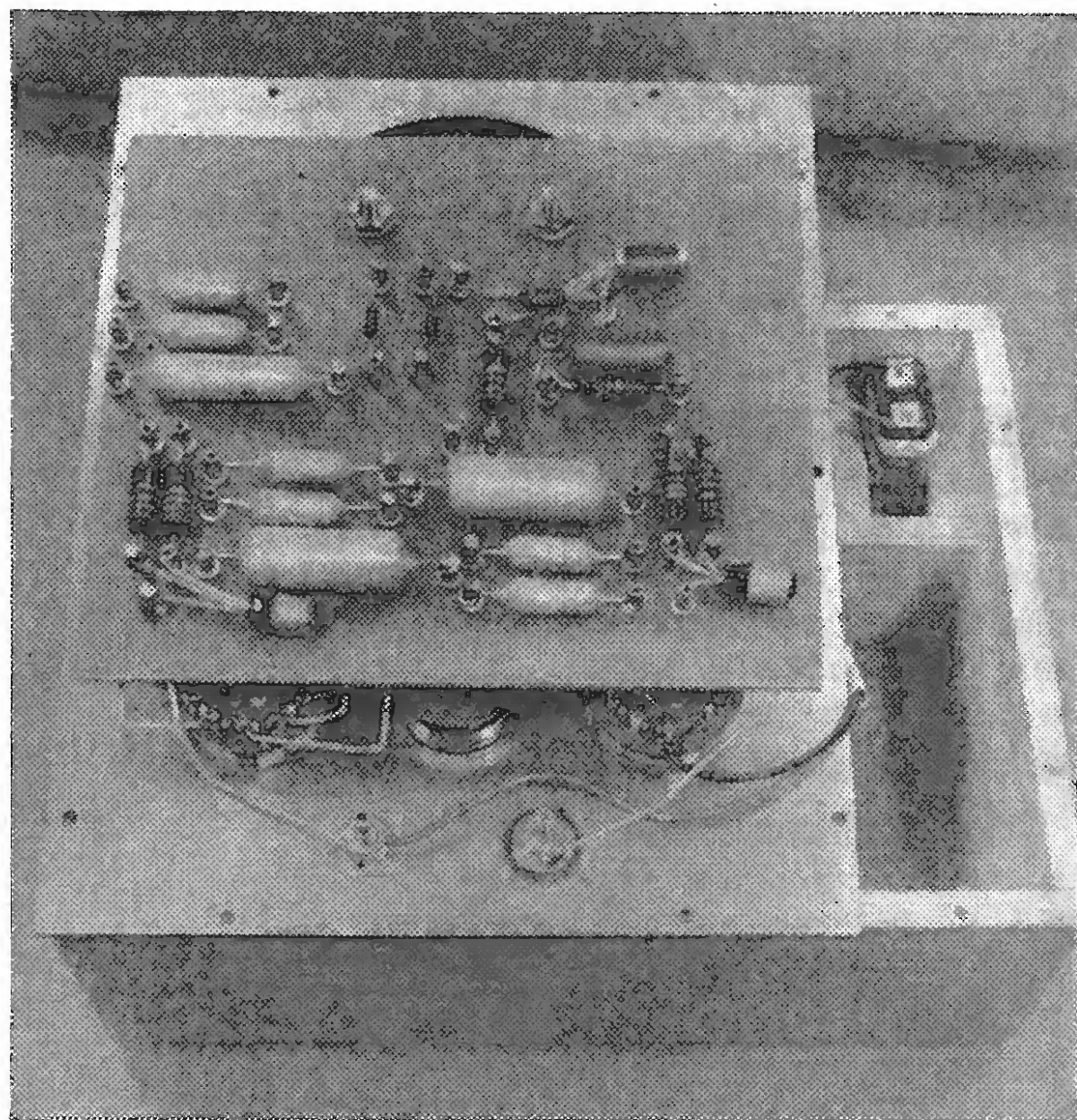

First prize in the Junior Section of the annual Constructors' Competition organized by the Welwyn Garden City Group of the R.S.G.B. was won by Trevor Baker, aged 16, with this version of the capacitance meter described in *Wireless World* in April 1964. He used Formica bonded to the non-copper side of a piece of printed-circuit board for the front panel; the copper being connected to the low-potential terminal to provide a hand-capacitance screen. Trevor Baker planned and produced a printed circuit board on which to mount the components.

Electronic Laboratory Instrument Practice

9.—AUDIO AMPLIFIER MEASUREMENTS

By T. D. TOWERS,* M.B.E., A.M.I.E.E., A.M.I.E.R.E.

UNDER the impact of British Standard 3860 : 1965 and the recommendations of the American Institute of High Fidelity Manufacturers (I.H.F.M.), audio amplifier measurements now begin to follow a common pattern. Where American and British practice differ, the British standard is followed in this article.

Output power

The measurement—like the design—of an audio amplifier must start with the output end. The first consideration is “*rated output power*,” i.e. the power the manufacturer or designer claims can be delivered continuously by the amplifier to a stated load resistance at 1 kc/s without the harmonic distortion rising above a specified limit. Typical distortion limits are 10% for “entertainment” applications, 1% for average high-fidelity and 0.1% for very high fidelity. To verify the rated output of an amplifier a 1 kc/s sinewave is fed through it at a level sufficient to produce the rated output power in a non-inductive load as specified by the manufacturer, and, after not less than 30 seconds, the harmonic distortion is measured by one of the methods described later in this article.

Another output characteristic of the amplifier, not to be confused with the rated output power, is the “*maximum output power*.” This is the power output at 1 kc/s that can be obtained when the level is raised until the output total harmonic distortion equals the limit used by the manufacturer for specifying the rated output power. Naturally the maximum should not be less than the rated power.

In the U.S.A., the term “continuous output power” is used synonymously with the British “maximum output power” to describe the greatest single-frequency power that can be obtained from an amplifier for not less than 30 seconds without exceeding its rated total harmonic distortion. Other terms formerly used for the same concept have been “sine-wave power,” “r.m.s. power” or “steady state power.”

Manufacturers have always tried to find more valid (or more customer-attractive?) methods of rating the power available from an amplifier than the continuous output power. The British Standard does not recognize these, but American practice is sometimes to specify a “music power output.” This is the greatest single-frequency power that can be obtained from an amplifier without exceeding its rated distortion where the measurement is made immediately after the sudden application of a signal and during a time interval so short that supply voltages within the amplifier have not changed from their no-signal values.

Another concept sometimes used (and beloved of advertising staff!) is the “peak power” rating. This can be taken as twice the corresponding single-frequency rating. For example, by the specific term “peak power rating” is usually meant twice the rated output power

defined earlier; similarly the “peak music power output” is twice the “music power output.”

As described in the last article (No. 8) of this series, the output power can be measured on an audio power meter or calculated from the r.m.s. voltage across the load resistance. In the latter case, a true r.m.s. reading meter should be used, and it is prudent to inspect the output waveshape with an oscilloscope to ensure that it is reasonably sinusoidal.

On the load resistance, the British Standard merely provides that it should not vary from its nominal value by more than 5% while dissipating any power up to the amplifier rating. The American I.H.F.M. recommends that it should be capable of dissipating the full output of the amplifier while maintaining its resistance within 1% of the rated value, but also that it will not have more than 10% reactive component at any frequency up to 5 times the highest test frequency.

The 1 kc/s input test signal to the amplifier should be sinusoidal and accurate in frequency to $\pm 2\%$. It should be low distortion relative to the amplifier distortion being measured, the B.S.I. recommendation being that the r.m.s. total of all components other than the fundamental should not be more than 1/5th of the expected harmonic distortion in the amplifier. This need for a pure test signal is sometimes overlooked, particularly in measuring high-quality, low-distortion amplifiers. I have known cases of apparently high amplifier distortion traced back to the generator. Conversely, I have known of high-distortion amplifiers measuring low because the generator and amplifier distortions balanced each other out.

In discussing output power we have tacitly assumed we are dealing with power amplifiers. For pre-amplifiers we are concerned with rated and maximum output voltages, but the same principles apply. The manufacturer specifies a rated output voltage which the pre-amplifier can supply at 1 kc/s without exceeding a stated limit of harmonic distortion. The maximum output voltage is the actual voltage output at this stated distortion limit.

Harmonic distortion (single tone)

In commercial amplifiers it is customary to consider the available output power in relation to the total harmonic distortion at that power.

The simplest (and fastest) method of measuring harmonic distortion is to use a commercial *distortion-factor meter* (also known as an harmonic-distortion meter or total-distortion meter). The basic arrangement of a distortion-factor meter is illustrated in Fig. 63(a). A single frequency sinewave from the a.f. generator (usually 1 kc/s) is applied to the amplifier under test. This signal should be as free of distortion as possible, and to this end a tuned filter is often interposed after the signal

*Newmarket Transistors Ltd.

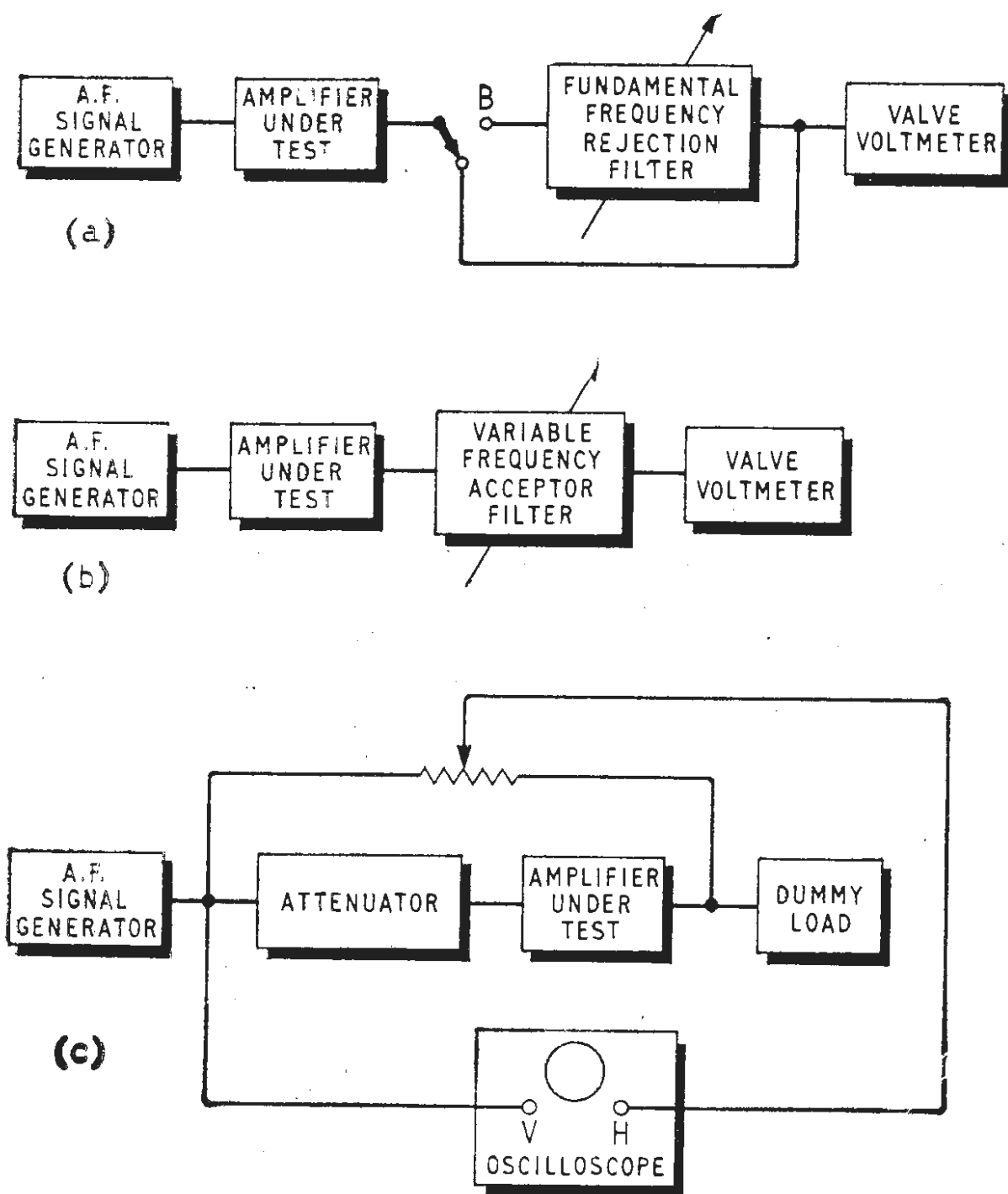

Fig. 63. Basic arrangements for different methods of measuring audio amplifier harmonic distortion: (a) distortion-factor meter; (b) wave-analyser; (c) "balance"-method.

generator. With the switch in position A, the amplifier output voltage (comprising fundamental and harmonic components) is measured on the valve voltmeter. The switch is then transferred to position B and the funda-

mental frequency rejection filter is tuned for minimum output voltage. The ratio of this minimum voltage (which represents harmonic components) to the first voltage (which represented fundamental plus harmonics) is computed to give the distortion percentage.

While distortion-factor meters are adequate for measuring total harmonic distortion, more refined testing requires that each harmonic in an amplifier output should be assessed separately. The "wave analyser" is the instrument normally used for separate measurement of each of a series of harmonics. Fig. 63(b) shows in diagram form the basic arrangement of the wave analyser. In this case the output signal from the amplifier is passed through a variable frequency acceptor filter which is tuned in turn to the fundamental and each successive harmonic. By this means it is possible to read off the comparative voltage of each frequency and compute the percentage of 2nd, 3rd etc. harmonics present individually in the amplifier output.

A third method sometimes used to measure harmonic distortion whose accuracy is much less affected by distortion in the input signal to the amplifier under test is shown in Fig. 63(c). This "balance-method" consists of balancing the fundamental of the amplifier output signal against the input signal at the vertical input of an oscilloscope. If no harmonic distortion were introduced by the amplifier, the vertical signal at the scope input would be zero, i.e. a horizontal line. Harmonics introduced by the amplifier gave rise to a vertical deflection trace which can be calibrated to give a direct visual indication of each harmonic. (The circuit shown assumes that phase inversion occurs across the amplifier.)

Commercial distortion measuring equipment can be expensive, but it is possible to build your own distortion factor meter reasonably easily. Fig. 64 gives a suggested three-transistor circuit with a Wien-bridge network to suppress the fundamental, and leave only the harmonics,

(continued on page 457)

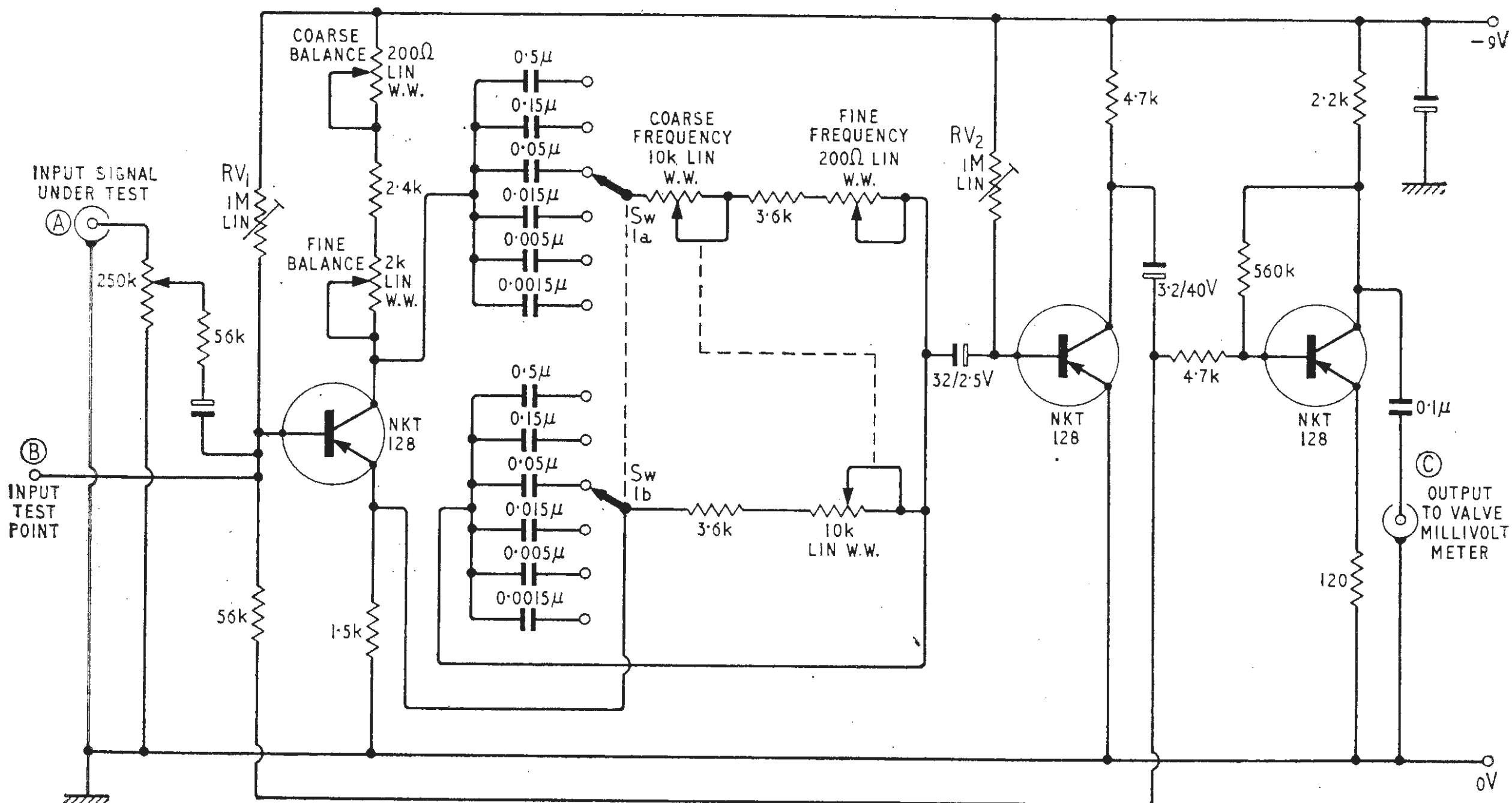

Fig. 64. Suggested circuit for transistor distortion-factor (total-distortion) meter covering 20-20,000 c/s.

of the signal under examination. With a 1 kc/s signal from the amplifier applied to the input point (A) the balance and frequency controls are adjusted for minimum reading on the valve voltmeter at the output point (C). The amplifier test signal is then changed to 2.5 kc/s (well beyond the second harmonic of 1 kc/s) and the level adjusted with the 250 k Ω input potentiometer until the output voltage reaches a convenient reference level, V_o (e.g. 1 V r.m.s.). The voltage V_b , at the base of the first transistor is also noted. The amplifier test frequency is returned to 1 kc/s and the input level adjusted (if necessary) to give the same base voltage, V_b . The balance and frequency controls are re-nulled and the resultant voltage, V_p , at the output measured. The percentage total distortion is then given by $(V_p/V_o) \times 100\%$. With a 1 V reference, a 10 mV reading represents $(10/1000) \times 100 = 1\%$ total distortion.

Sensitivity

The sensitivity of an audio amplifier is nowadays (following the British Standard) often specified in terms of a "sensitivity voltage," i.e. the e.m.f. applied in series with the stated source resistance, to the input terminals in order to obtain the rated output power or voltage. Note that for a sensitivity voltage specification you must define the source impedance and the rated output power. Sensitivity voltage is measured as shown in Fig. 65(a), where V_s is the e.m.f. from a voltage (low impedance) source which, when applied *via* the specified source

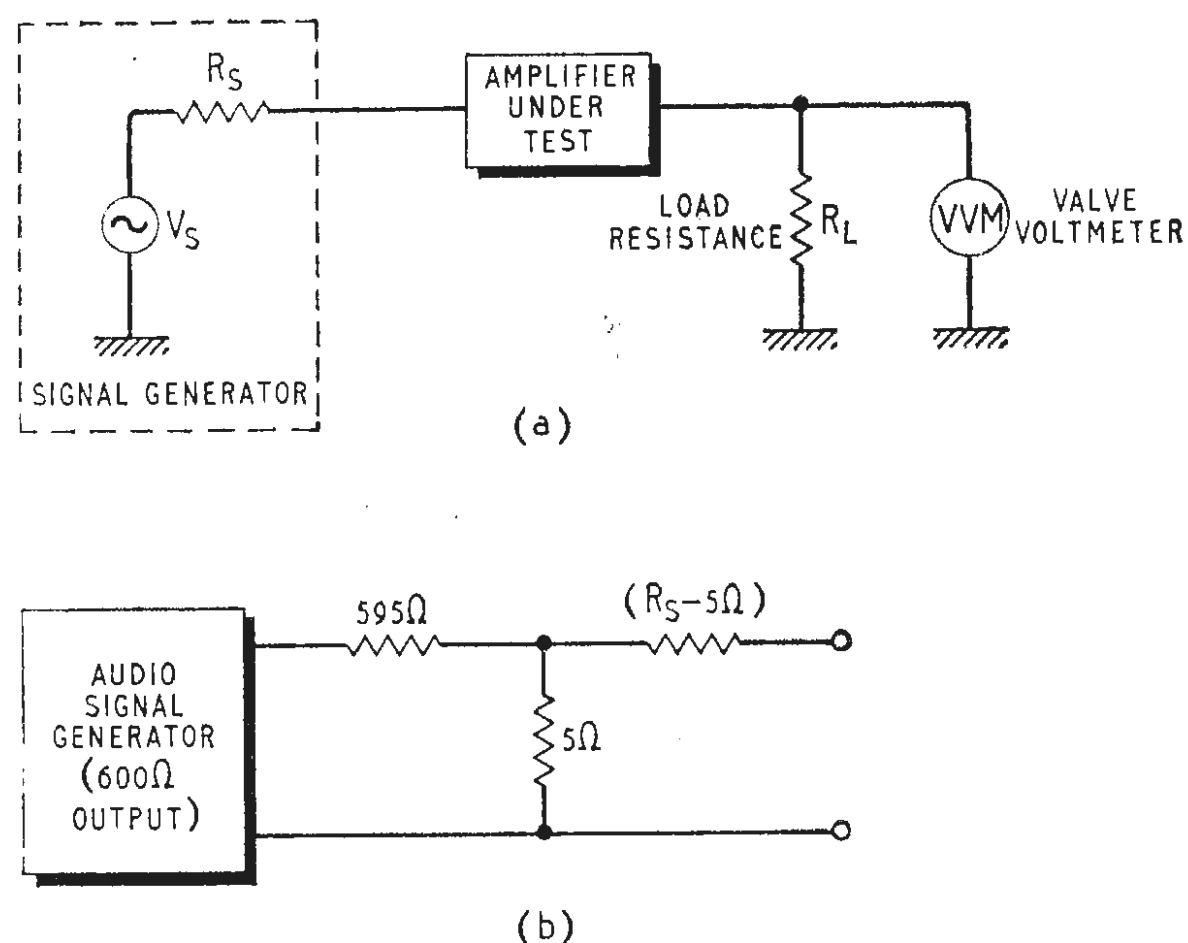

Fig. 65. Sensitivity voltage measurement:— (a) general arrangement; (b) simulating a source resistance R_s with a standard 600 Ω audio generator.

resistance R_s to the amplifier, gives the rated power output as measured by the valve voltmeter across the specified load, R_L . A practical arrangement to provide the correct generator drive is shown in Fig. 65(b). It should be noted that the sensitivity voltage is *not* the voltage at the input of the amplifier, but is the voltage applied to a source resistance in series with the amplifier input. Even some experienced engineers are confused on this point.

Gain

A concept related to sensitivity is amplifier gain. The British Standard recommends the use of "transducer"

gain, G , with defined source and load resistances. This is measured with the same arrangement as for sensitivity in Fig. 65. The source e.m.f., fed into the amplifier via the defined source resistance R_s , is adjusted to a value V_s for which the output voltage V_o across the load resistance R_L gives an output power one tenth (10 dB down) of the amplifier's rated output power. The maximum available power from the source (obtained only if the amplifier input resistance exactly equals the source resistance) is $P_s = V_s^2/4R_s$, and the power in the load is $P_o = V_o^2/R_L$. The transducer gain G (in dB) = $10 \log_{10}(P_o/P_s)$. Once again, note that the gain defined here is not the ratio of output power to amplifier actual input power.

The gain of a pre-amplifier is measured in the same way. A source of e.m.f. fed through a specified source resistance is adjusted until the pre-amplifier output voltage, measured on a high impedance meter, is 0.707 (i.e. 12 dB down) of rated output voltage. The transducer gain is then calculated as before.

It scarcely needs pointing out that in all amplifier measurements unless specifically stated otherwise, any volume control should be set for maximum gain.

Frequency-amplitude response measurements

Frequency response measurements rank with distortion measurements in assessing amplifier fidelity. They fall into two main categories, referred to as (a) "power bandwidth" and (b) "bandwidth."

Power bandwidth is the curve of maximum output power (for the defined total distortion) versus frequency, plotted with logarithmic scales on both axes. The British Standard recommends that measurements should be made up to 5 kc/s. The lowest value of maximum output power on this curve is of interest because it is used in the measurement of bandwidth discussed below. The measurement of the power bandwidth response reduces itself to measuring the maximum output power as described earlier over a range of frequencies instead of at the normal 1 kc/s reference frequency.

Bandwidth relates to the variation of amplifier sensitivity with frequency. For this measurement, the amplifier controls are first set "flat"—i.e. gain control at maximum and tone controls or filters set for most uniform frequency response. A 1 kc/s sinusoidal signal is then applied to the input and adjusted in amplitude to a specified output power, which must not be more than the minimum noted on the power/frequency curve referred to above. (American practice here is to set a 1 kc/s output power at least 10 dB down on the rated output power and not less than 20 dB above residual noise.) The input signal frequency is then varied in steps above and below 1 kc/s over the frequency range of interest and the change in sensitivity voltage (i.e. e.m.f. into source resistance into amplifier) necessary to keep the output constant is measured in decibels. This change in decibels (reversed in sign) is plotted on a linear vertical scale against frequency on a logarithmic scale. The "bandwidth" is often popularly specified as the lower and upper limit frequencies where the sensitivity has dropped by a certain amount—frequently 3 dB—from the 1 kc/s value.

Typical 3 dB bandwidth specifications are

- (a) Telephone 300-3500 c/s; (b) Radio receivers etc. 100-4500 c/s; and (c) "Average" hi-fi 20-20,000 c/s.

Frequency response tests can be carried out using conventional good-quality signal generators and valve voltmeters, but the plotting of results is time-consuming.

Commercial equipment is available in the form of strip chart recorders, which can produce a pen record in a few minutes and wobblers which display an instantaneous scope trace of the frequency response.

Intermodulation or two-tone distortion

With a single frequency tone, non-linearity in an audio amplifier gives rise to harmonic distortion discussed earlier. When two separate single-tone audio frequencies are fed simultaneously through the amplifier, a new kind of distortion, "intermodulation distortion," arises from the non-linearity. The a.f. components interact and give rise to sum and difference frequencies as well as the two fundamental test frequencies and their harmonics. For example, in an amplifier with intermodulation distortion, the feeding of 100 c/s and 5,000 c/s input signal will produce significant outputs not only at the two test frequencies but also at 4,900 and 5,100 c/s. Such distortion is the more objectionable in that it introduces frequencies not harmonically related to the test frequencies. Until the issue of B.S. 3860:1965 several different methods of measuring intermodulation distortion were used, but the preferred method is now the "high-low" frequency one. In this a small high-frequency signal (about 5,000 c/s) is applied to the amplifier together with a large low frequency one (about 100 c/s) of four times the amplitude. The intermodulation distortion percentage in the output can be arrived at by filtering out the two test frequencies and computing the residual r.m.s. signal as a fraction of the full r.m.s. output. This gives the total intermodulation distortion, but a wave analyser can also be used, as with harmonic distortion, to evaluate the separate frequency components of the total.

Commercial intermodulation distortion test sets are available, but anyone interested in doing a few intermodulation tests can set up the arrangement in Fig. 66 with instruments available in most laboratories. Fig. 66(a) shows frequencies of 100 and 5,000 c/s with a 4 : 1 amplitude ratio being fed into the amplifier via a balanced bridge which prevents intermodulation distortion at the input. The bridge transformer is a high-quality 1 : 1 audio isolating transformer and the four 680 Ω resistors must be carefully equalized to isolate the two signal generators. The amplifier output is fed

through a high-pass filter to reject the low frequency. Fig. 66(b) shows an RC filter circuit used by the author for 100 c/s rejection. The residual modulated 5,000 c/s signal is fed to the scope vertical amplifier and its time base synchronized direct from the 5,000 c/s generator. The scope trace is shown in Fig. 66(c) with the method of computing the percentage intermodulation distortion.

Crossover distortion

With the recent popularity of transistor amplifiers "crossover distortion" has been much bandied about. I have heard some claim that it is a form of intermodulation distortion, but one should be clear on this point—it arises with a single frequency signal and is a form of harmonic distortion. A sinewave input as Fig. 67(a) becomes transformed to the waveshape at Fig. 67(b). Why it is called "crossover" distortion should be clear from the little plateau in crossing over the zero axis. In most forms of harmonic distortion the higher harmonic distortion components are usually relatively small, but with cross-over significant components can sometimes be found out to the fifth and higher harmonics. This should be remembered when using a wave analyser as it is possible to overlook these higher harmonics.

Hum

Hum in an amplifier output is usually measured with a voltmeter or power meter isolated from the amplifier output by a low-pass filter passing only up to the fourth harmonic of the power supply frequency, i.e. to 200 c/s in the United Kingdom. The meter should preferably be true r.m.s. reading. (A wave analyser may also be used, and the hum voltage computed from the square root of the sum of the squares of the component voltages.) The hum level of the amplifier is specified in decibels relative to the rated output of the amplifier when the input is terminated with a standard value resistor (which should be a low-noise high-stability resistor screened to prevent stray hum pick-up). The standard resistor is usually made equal to the source resistance of the input transducer for which the amplifier is designed.

The r.m.s. meter plus low-pass filter method of measuring hum can lead to erroneous readings because it does not discriminate against noise in the low-frequency

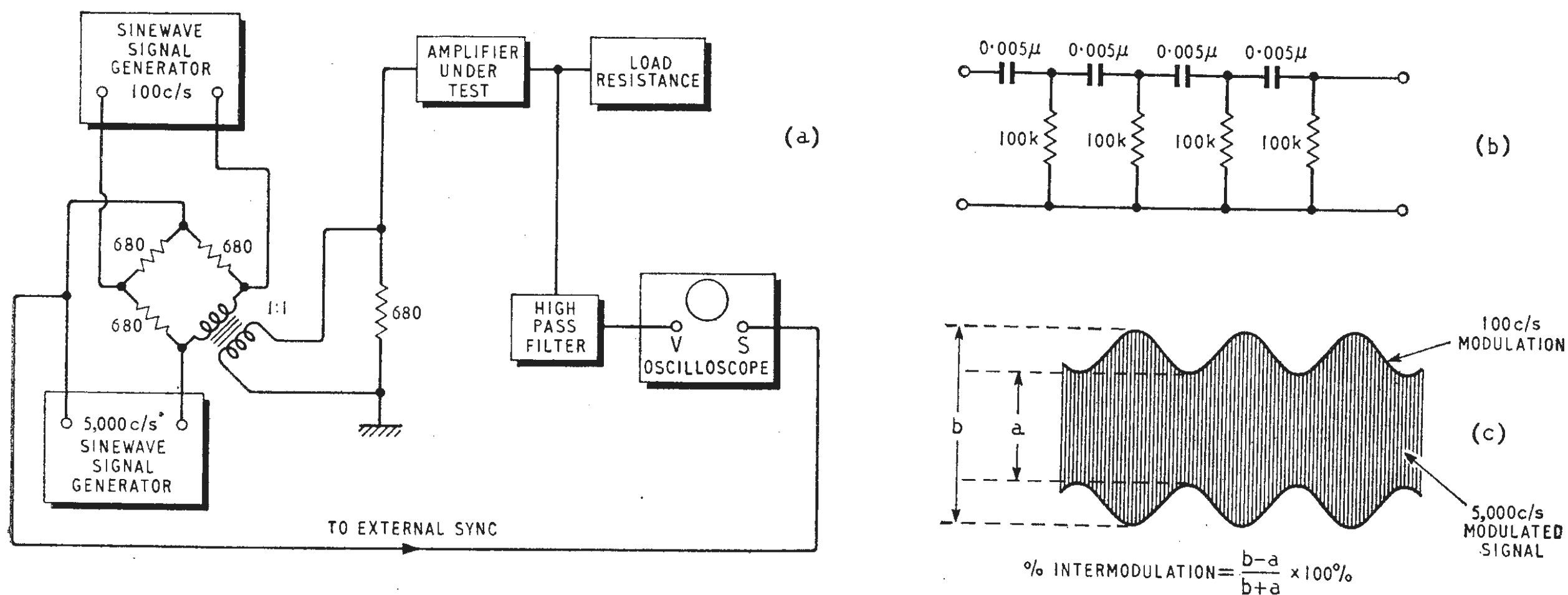

Fig. 66. One experimental arrangement for measuring intermodulation distortion:— (a) general block diagram; (b) RC high-pass filter for 100 c/s rejection; (c) intermodulation distortion computed from 100 c/s modulation depth on 5,000 c/s.

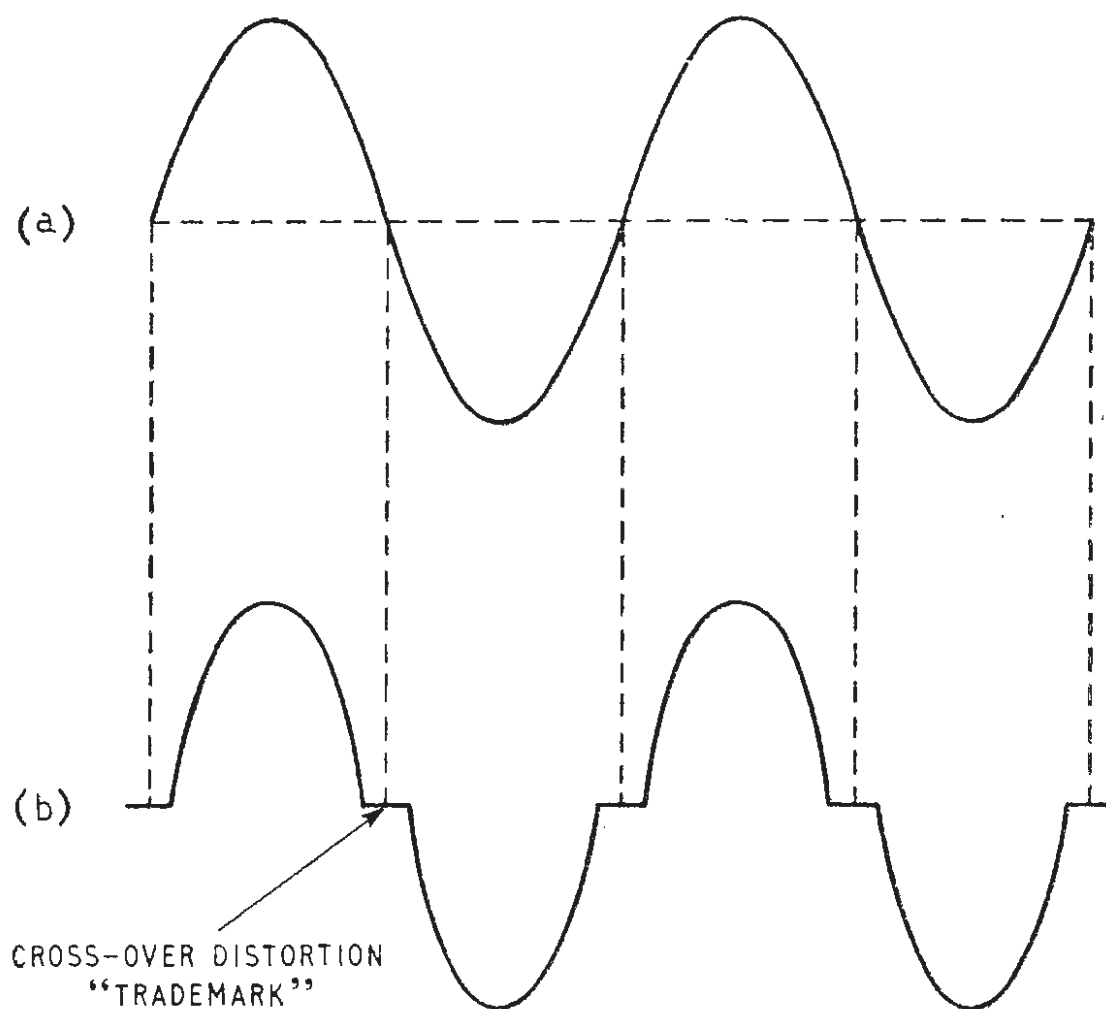

Fig. 67. "Crossover" distortion waveforms:— (a) input sinewave; (b) output waveform with significant crossover distortion.

passband of the filter. For this reason it is usual to inspect the hum voltage on a scope at the same time to ensure no significant noise signals.

Noise

Apart from hum, noise in an amplifier system may show up as hissing, crackling, popping, etc. It is usual to treat "noise" as not including hum, and such noise output may be measured with an r.m.s. voltmeter or power meter isolated from the amplifier output by a high-pass filter that effectively removes hum components. As with hum measurements, the input should be terminated with a specified resistance.

The simple high-pass filter method treats all noises in the spectrum in the filter passband equally, but owing to the selective hearing of the human ear, a better indication of the noise assessment of an amplifier is obtained by using a selective high-pass filter which still blocks hum voltage but accentuates noise at the frequencies where they have the most effect on the normal listener. This gives rise to a "weighted noise output voltage" instead of a simple noise output voltage, but, except for the filter design, measurement methods are the same as for unweighted noise.

The noise output power (r.m.s. voltage into load resistance) expressed in decibels down relative to the rated output power is one index of the noise performance of the amplifier. Another index sometimes used is the "equivalent noise input voltage". This is the input voltage at 1 kc/s in series with the stated source resistance that would produce an r.m.s. output voltage across, or power in, the stated load resistance equal to that produced by amplifier noise. To measure the equivalent noise input voltage a 1 kc/s sinewave test signal voltage, V_s , is applied to the amplifier input *via* the specified source resistance, to produce an output voltage, V_o , across the load resistance R_L , such that the output power is less than the rated output power of the amplifier. The test signal is then removed and the input terminated by a screened resistor (usually equal to the source resistance). Under these conditions, an r.m.s. noise output voltage V_N is read. The equivalent noise input voltage is then equal to $(V_s \times V_N)/V_o$.

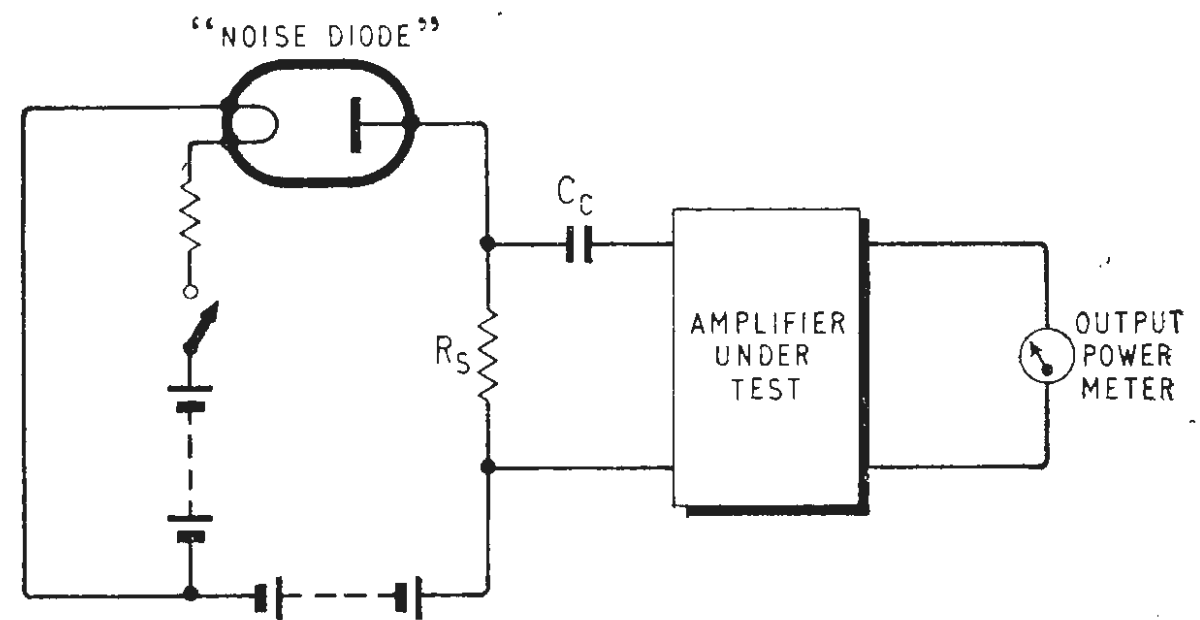

Fig. 68. Noise figure measurement circuit.

Another way of specifying the noise performance of an amplifier is by means of its "noise factor". This is the ratio of the total r.m.s. noise output voltage to that part of it which is due to the thermal noise of the source circuit treated as a passive network at 290°K over the frequency range of the amplifier. The noise factor, N , can be measured using a noise generator (generally a saturated thermionic diode) and an output meter arranged as shown in Fig. 68. The resistor R_s should be within 5% of the specified amplifier source resistance, and the coupling capacitor C_c should be not less than $3300/R_s$ microfarads (where R_s is in ohms). The noise output is first measured with the diode filament cold. The filament current is then increased until the noise output power is increased by a convenient factor P (usually $\times 2$) and the diode current I_D (amps) is measured. If the resistor R_s is at 290°K (normal room temperature), the noise factor N expressed as a numerical ratio is given by $N = 20I_D R_s (P - 1)$. Often N is expressed in decibels rather than as a pure ratio.

Impedances

The *input impedance* of an amplifier is the impedance looking *into* the amplifier input. It is difficult to measure because in many cases the impedance being measured can depend upon the source impedance presented to the amplifier input by the measuring circuit. An impedance bridge may be used, but it is essential to see that it presents the proper source impedance to the amplifier input. So far as the input resistance is concerned a simple method of measuring this is shown in Fig. 69(a). A sinewave voltage input V_s at the test frequency (usually 1 kc/s) is applied *via* a specified source resistance R_s to give an output below the rated output power. The source open circuit voltage V_s being known, the voltage

Fig. 69. Measuring input and output resistances of any audio amplifier:— (a) input resistance; (b) output resistance.

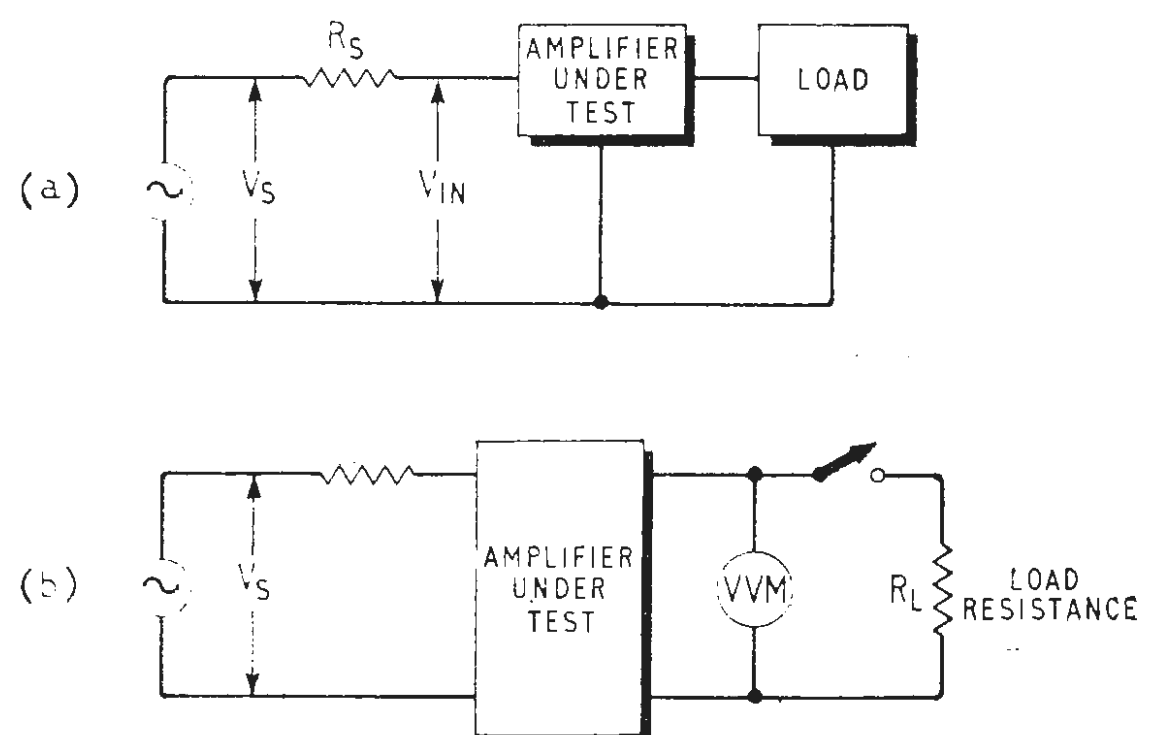

V_{IN} at the amplifier is also noted, and the input resistance computed from $R_{IN} = R_S \cdot V_{IN} / (V_S - V_{IN})$.

Amplifier output impedance too can be measured with an audio-frequency impedance bridge, but in the absence of such an instrument the arrangement shown in Fig. 69(b) can be used for measuring output resistance. A 1 kc/s source being applied to the input, the output voltage, $V_{O'}$, with no load attached, and V_O with the specified amplifier load R_L are measured. Then the amplifier output impedance, R_{OUT} , is given by

$$R_{OUT} = R_L (V_{O'} - V_O) / V_O$$

Connected with the amplifier output resistance is its "damping factor", i.e. the ratio of the specified load resistance to the output impedance (assumed to be resistive) of the amplifier at a stated frequency. The damping factor is usually measured at 50 c/s. A 50 c/s signal is applied to the input to produce one quarter of the rated output power in the specified output load resistance. Let V_O be the output voltage for this. Now remove the output load, keeping the input signal constant, and let the measured open circuit output voltage be V_i . Then the damping factor, F_D , is given by

$$F_D = V_O / (V_i - V_O)$$

Stability

An important thing to check, especially in professional audio amplifiers, is the stability margin and whether the amplifier behaves satisfactorily towards both ends of the frequency response. The stability test prescribed by B.S.3860:1965 is to operate the amplifier without a load but with a capacitor connected across the output terminals. Where the amplifier is claimed to be unconditionally stable, the capacitor load is varied by steps of $0.01 \mu\text{F}$ from 0.01 to $0.1 \mu\text{F}$, and by steps of $0.1 \mu\text{F}$ from 0.1 to $1 \mu\text{F}$ for a nominal 15Ω load. For other stated loads these values should be adjusted inversely as the load resistance. Where no claims of stability are made, the capacitor should be such that its reactance at 200 kc/s is equal to the nominal load impedance, e.g. $0.05 \mu\text{F}$ for a 15 ohm load. The actual test of stability when the amplifier is capacitor-terminated is to inspect the output voltage in an oscilloscope to ensure no spurious oscillations, first with no input to the amplifier and then with a signal varying from 10 c/s to 70 c/s in frequency and an amplitude equal to the sensitivity voltage (see earlier) at 1000 c/s.

One popular method of amplifier stability assessment is "square-wave testing" in which a suitable square wave is applied to the input, and the output inspected on an oscilloscope screen. To reproduce faithfully a square wave of frequency f the amplifier must be capable of passing frequencies down to $f/10$ and up to $10f$. A little thought is therefore required in selecting the square wave repetition frequency. For example, 1 kc/s is suitable for a general test on an amplifier with a bandwidth from below 100 c/s to above 10 kc/s. A square wave can be regarded as made up of an infinite number of odd harmonic related sinewaves, and therefore an amplifier being tested with square waves is being checked simultaneously at a number of frequencies. Some experience is necessary to interpret the significance of output distortion of a square wave, but as a rough generalization rounded leading edges indicate poor high-frequency response, upward tilt of the wave tops, excessive l.f. response or bass boost and downward tilt or "droop" poor low-frequency response. If the output has spikes, "ringing", or damped oscillations on the wave tops, the amplifier may have excessive high-frequency response, excessive amplification in some band of frequencies or instability.

Precautions

In all audio amplifier measurements it is important, especially in low-level measurements (such as hum or noise) to ensure that the measurement technique does not give rise to spurious effects such as hum introduced by a ground loop formed between the instrument and the amplifier.

In all distortion measurements always measure the distortion of the signal generator itself to verify it is not less than five times down on the amplifier distortion.

Always check the calibration of any instruments before making exact measurements. Some things, like the accuracy of the frequency setting of your generator, are seldom questioned, but a few weeks before writing these words the author found the explanation for some curiously inconsistent amplifier response results in a standard commercial signal generator that gravely showed 9 kc/s on its setting dial while it delivered a steady 6 kc/s from its output terminals!

Finally if you have occasion to carry out any substantial tests in audio amplifiers, buy a copy of B.S.3860:1965 and consider its recommendations very carefully. In this also you will find described a number of other tests sometimes carried out on such amplifiers which could not be covered in this article.

Commercial Literature

A 52-page catalogue containing electrical and mechanical design information on the "valves and cathode ray tubes for industry" manufactured by the M-O Valve Company, of Chelmsford, has been forwarded to us.

9WW 321 for further details.

"Simplification of Biasing Circuits using Transistors BCY42 and BCY43" is the title of an application note available from the Semiconductor Division of Standard Telephones and Cables Ltd., Footscray, Kent. The transistors mentioned are low level silicon epitaxial planar types with a two-to-one spread in gain, at a collector current of 1 mA.

9WW 322 for further details.

"SESCO Semiconducteurs."—This 44-page catalogue contains details of many hundreds of semiconductors ranging from signal diodes and rectifiers to thyristors and u.h.f. transistors. Also included are thin film circuits, microwave diodes, photosensitive devices and ring modulators. Copies of this catalogue are obtainable from SESCO's (Société Européenne des Semiconducteurs) U.K. representatives M.C.P. Electronics Ltd., Station Wharf Works, Alperton, Wembley, Middx.

9WW 323 for further details.

"Magnetic Recording Heads" for computers, data recorders, simulators and magnetic drum information storage units are described in a new series of data sheets issued by Gresham Lion Electronics Ltd. Binders containing these data sheets (A4) are available from the company's magnetic recording head department, Lion Works, Hanworth Trading Estate, Feltham, Middx. Eleven types of head for digital and analogue applications with up to 33 tracks per inch are included.

9WW 324 for further details.

The "Brimar Valve and Cathode Ray Tube Manual, Number 10" is now available, price 7s 6d, from the Brimar publicity department of Thorn-AEI Radio Valves and Tubes Ltd., of 155 Charing Cross Road, London, W.C.2. Industrial cathode-ray tubes and industrial switching transistors have been added for the first time to this publication, which contains 416 pages and gives design data on 629 different valves and c.r.t.'s. An equivalents list containing over 1,200 commercial and CV types is included.

SELF-CONTAINED TELEPHONE SCRAMBLER

THE picture shows a portable voice scrambler recently introduced in America to combat the invasion of telephone privacy by line tapping—a subject of growing concern in the U.S.A. and not unheard of in Britain. The transistor battery-powered device is self-contained and requires no electrical connections to the telephone handset, the scrambled speech being transmitted acoustically to and inductively from the handset. A conversation is only possible when two correspondents have identically coded scramblers. Names of people and firms owning scramblers, and the codes used, are kept secret by the manufacturers. Weighing 26 oz, and containing a power pack of mercury cells with a life of 100 hours, the portable scramblers are manufactured and supplied by the Delcon Division of Hewlett-Packard, Palo Alto, Calif., at a price of \$550 per pair.

In the U.K. the Delcon scrambler has not been approved by the Post Office for use with the public telephone system (under the official telephone regulations legal action can be taken against people using unauthorized attachments or accessories) but, of course, no such restriction applies to private telephone systems. The Post Office has, however, approved a British transistor scrambler equipment, the Secraphone



made by T.M.C., which requires electrical connections from the subscriber's instrument to a small unit (6in×4in×10in) and two switches on the instrument.

NEW THIN FILM MATERIAL

BETA TANTALUM is the name given to a recently discovered variant of the metal tantalum which may prove useful as a resistive material in integrated circuits. Discovered by workers in Bell Telephone Laboratories and Western Electronic Engineering Research Centre, U.S.A., the new material has a higher resistivity and a lower temperature coefficient of resistance than ordinary tantalum, and it becomes a superconductor at a much lower temperature (0.5°K instead of about 3.3°K). Like normal tantalum, it could be used to make thin-film capacitors because it readily forms oxides and can be anodized by the usual techniques.

So far, beta tantalum has been produced only in film form. Most of the experimental data has been collected from films produced by cathode sputtering, although the material has also been observed in films made by evaporation and chemical vapour deposition processes. When the films are formed in a sputtering system containing argon at a pressure of 10×10^{-3} to 30×10^{-3} torr, beta tantalum is frequently

observed when the total pressure of other gases in the vacuum system is less than 1×10^{-5} torr.

Beta tantalum formed by sputtering has a resistivity ranging from 180 to 220 $\mu\Omega$ cm, and a temperature coefficient ranging from -100 to $+100$ p.p.m./°C. In contrast, normal sputtered tantalum films have a resistivity in the range of 24 to 50 $\mu\Omega$ cm and a temperature coefficient in the range of $+500$ to $+1800$ p.p.m./°C.

The new material has a more complicated crystal structure than normal tantalum, but converts to normal tantalum when heated in a vacuum to about 750°C.

SOLID-STATE IMAGE SENSING PLATE FOR CAMERA

THE National Aeronautics and Space Administration of the U.S.A. are experimenting with a small television camera which uses a solid-state image sensing panel in place of the conventional electron-beam pick-up tube. Presumably they plan to use it in observation spacecraft instead of vidicon cameras (which were installed in Mariner IV to take pictures of the planet Mars and in the Ranger series to photograph the moon). The image sensing plate is a mosaic of 2,500 phototransistors, measuring 0.5 in×0.5 in, and has an image resolving power of 100 lines per inch of plate. The mosaic is an integrated-circuit 50×50 configuration, formed by 50 transistor collector structures running the length of the plate, each having diffused into it 50 individual base-emitter structures with 50 deposited metal conductors for the emitters running across the plate at right angles to the collector strips. The collector strips are diffusion isolated from each other.

Integrated-circuit structures are also used to provide the panel scanning circuits. A video output signal is obtained by sequential switching of a bias voltage to the phototransistor electrodes. The complete camera, which measures 6 in×4 in×2½ in and uses a standard 16-mm lens, has been developed for N.A.S.A. by Westinghouse.

RESONANCE RECTIFICATION

THE phenomenon of "resonance rectification" occurs when an alternating potential is applied to a probe situated in a plasma. A direct current flows in the probe which reaches a maximum value as the frequency of the applied potential is varied through the plasma frequency. The phenomenon is being studied at the Radio & Space Research Station of the U.K. Science Research Council and is referred to in the annual report entitled *Radio Research 1964* (H.M.S.O.).

Theories have been proposed to explain the effect but none so far seem very satisfactory and some rely on the assumption of an unrealistic plasma sheath. An approach has been made which does not require the sheath postulate and a solution has been obtained for the frequency variation of the rectified current and admittance using a spherical probe. It was demonstrated that the direct current reached a maximum when the frequency had a value about two-thirds of the plasma frequency. Initial results using a Skylark rocket with a 2½ in disc probe showed little evidence of a resonance. Later experiments carried out with a spherical probe of 1 in dia. carried 3 ft in front of the payload, showed that the probe behaved roughly as expected, although the magnitude of the current peak and its width did not appear to be as predicted. A sample record showed a peak at 2 Mc/s. Many of the experimental facts about this phenomenon are still confusing and the results of the experiments are still being worked out in detail.

NEW PRODUCTS

equipment systems components

Military H.F. Transceiver

THE multi-purpose A13 radio set developed by Plessey in conjunction with the Signals Research and Development Establishment of the M.o.A. for military applications is now in full production and has been officially accepted by the British Armed Forces. Many accessories are available for the A13 making the



one-man pack, in its simplest form, into a mobile radio station.

Phase modulation is employed and is said to improve the equipment's range over that of amplitude modulated transceivers for a given power consumption. In fact, Plessey's claim an improvement of up to 30% in ground wave coverage is obtained for the same power consumption. Provisions are, however, made for a.m. working to enable the A13 to be used in current military systems. Provisions are also made for c.w. working and speeds of up to 25 w.p.m. are possible.

Simple free-running tuning is one of

the main features of this transistor transceiver, which covers 2 to 8 Mc/s and offers a choice of 2,400 (2.5 kc/s) channels. Calibration markers are provided at 100 kc/s and 10 kc/s intervals. The transceiver is powered by a 12-volt nickel-cadmium battery that can be quickly recharged from either a vehicle's

supply or from an ancillary hand generator. Output power of the transceiver is 1.5 watts, giving a working range in open country of five miles. With a transmit-receive ratio of one to nine the basic transceiver has an operational life of 8 hours per charging.

An r.f. power amplifier may be added to the simple one-man pack (as shown in the photograph) to increase the power output to 16 watts. Although this power amplifier has its own 12-volt battery, the operational life of the A13 is then reduced to 6 hours per charging, with a transmit-receive ratio of one to nine. The normal working range using the amplifier and a standard 8ft whip aerial

is 15 miles. Several other types of aerial are available, including two 150ft lengths of braid for long-distance working.

The basic unit is built on modular lines, making extensive use of printed circuit boards to simplify servicing.

Using another of the optional items, the harness adaptor unit, the A 13 will provide reliable vehicle communication. When installed, the equipment is powered from the vehicle's supply, via a regulator unit, another optional item. This provides a stabilized 14.4 volts from a nominal 24-volt source.

9WW 301 for further details

TAPE/DISC UNIT

SUITABLE for use with most types of ancillary equipment for producing background music, is the new tape/disc unit Type G/CD2 from the Coventry Shop Equipment Company, of 66 Canterbury Street, Coventry, Warks.

A Planet half-track, $3\frac{3}{4}$ in/sec tape deck is employed and—using 7-in spools with 2,400 ft of tape—offers four hours of non-repeat playing time. Automatic track reversal is provided, but no recording or fast wind facilities are included.

The associated disc deck is a Garrard Type 3,000 LM. Either a Ronette TX88 or one of the Decca Deram mono cartridges is fitted as standard.

A transistor power supply unit, to feed the tape head pre-amplifier and the relays, is also included in the



G/CD2, which measures $20 \times 16 \times 13\frac{1}{2}$ in. Weight is approximately 40 lb.

The price ex works is £145. Ancillary equipment, including a range of Leak amplifiers in strong wooden cases, can also be supplied.

Several other items of equipment for producing background music, including one which has an integrated f.m. tuner, are available from the Coventry Shop Equipment Company.

9WW 302 for further details

Hall Effect Devices

TWO field probes and two multipliers using Hall Effect techniques are being manufactured by the Electronics Group of Associated Electrical Industries Ltd., of Carholme Road, Lincoln. The semiconductor material selected for these devices is indium arsenide which offers stable performance over a wide temperature range and has good power efficiency characteristics.

The field probes comprise a thin semiconductor plate mounted on a beryllia backing which has a high electrical resistivity and a high thermal conductivity—equivalent to that of aluminium. Input and output resistance of the two devices is between 4 and 20 ohms, hence the effective output induction area is negligible, thus ensuring minimal a.c. pick-up from external sources. Power dissipation of up to 500 mW (200 mW for the smaller unit) can be tolerated, and with a field of 10 kilogauss, the Hall output is approximately 2.5 volts. Temperature coefficient for the two devices (designated field probe Mk. II and miniature

field probe Mk. III) is 0.1% per degree Centigrade (between 20°-60° C).

A semiconductor magnetic circuit combination, which accepts two inputs in the form of electrical currents (preferably from relatively high impedance sources), is used in the multipliers to obtain an output voltage proportional to their product at a level suitable for amplification by either valves or transistors. Two standard types of multiplier are available differing only in the nature of their coil windings; the Type A being suitable for valve circuits and Type C for transistor applications. Both types are potted in resin, and are fitted with an International Octal valve base.

In addition to their use in analogue computers and for power measurement, these multipliers can also be used in modulation and frequency changing circuits; producing a minimum of unwanted harmonics. Other possible uses are as linear or square law detectors, for frequency analysis and in d.c. to a.c. converters.

9WW 303 for further details

SPEAKER ENCLOSURE

SPECIALLY designed for high fidelity enthusiasts with space problems is the "Minette" enclosure from Richard Allan Radio Ltd., of Bradford Road, Gomersal, Nr. Leeds, Yorks. This speaker unit is unconventional in as much as the duralumin front panel of the enclosure forms an integral part of the bass unit by supporting the cone assembly.

The bass unit is five inches in diameter and its cone is suspended on a flexible Neoprene surround, which is glued to the front panel and, in free air, resonates at 40 c/s. The magnet assembly of the speaker is attached to the front panel by four pillars and is claimed to overcome the normal chassis resonances. A ceramic magnet is used and provides a flux density of 14,000 gauss on a one-inch diameter pole and a total flux of 56,000 Maxwells.

The tweeter in this enclosure is a specially developed version of the 460T unit and has a flux density of 6,000 gauss on a 9/16-in pole, the cone being mounted on a Cambric suspension.

A five-element cross-over network is employed and brings the tweeter in at approximately 5 kc/s. The complete unit is said to have a flat response from 80 c/s to 12 kc/s, although the overall frequency response is quoted as 45 c/s to 20 kc/s. Continuous r.m.s. power rating is 6 watts and music power rating

is 10 watts. The overall dimensions of the "Minette," which costs £17 10s 6d, are 11½ × 7 × 6¼ in. Weight is 11 lb.

To meet the needs of the home constructor, it is hoped to market the front

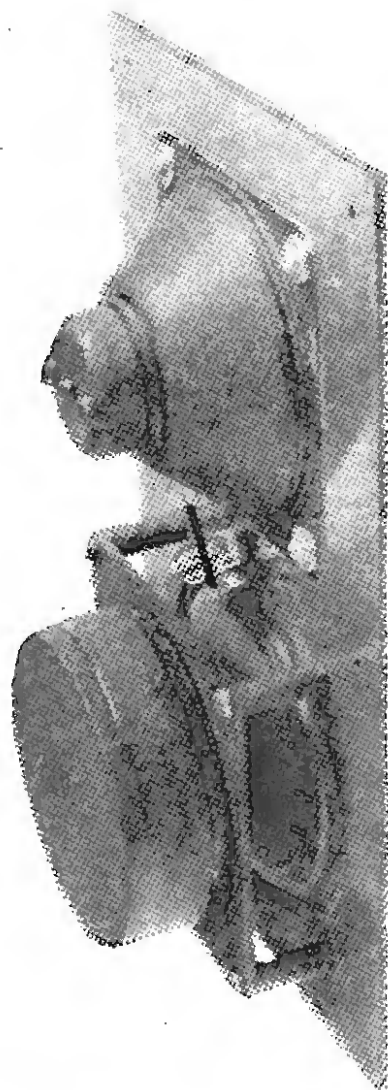

panel assembly, complete with speakers, but without the cabinet. The price has not yet been fixed, but it is understood it will be a little over half the complete price.

9WW 304 for further details

R.F. BRIDGE

USING transformers to obtain accurate voltage and current ratios, to compare an unknown capacitance and conductance with internal standards, the new wide-range bridge by Wayne Kerr offers 0.1% accuracy for capacitance and conductance measurement between 100 kc/s and 1 Mc/s. This instrument, designated B201, can also be operated, but with reducing accuracy, up to 5 Mc/s. Capacitance range is 0.0001 pF to 0.1 μF and the conductance range is 0.001 μmho to 1 mho. Internal modulation is at 1 kc/s.

A neutral terminal is provided on the connection block that allows three ter-

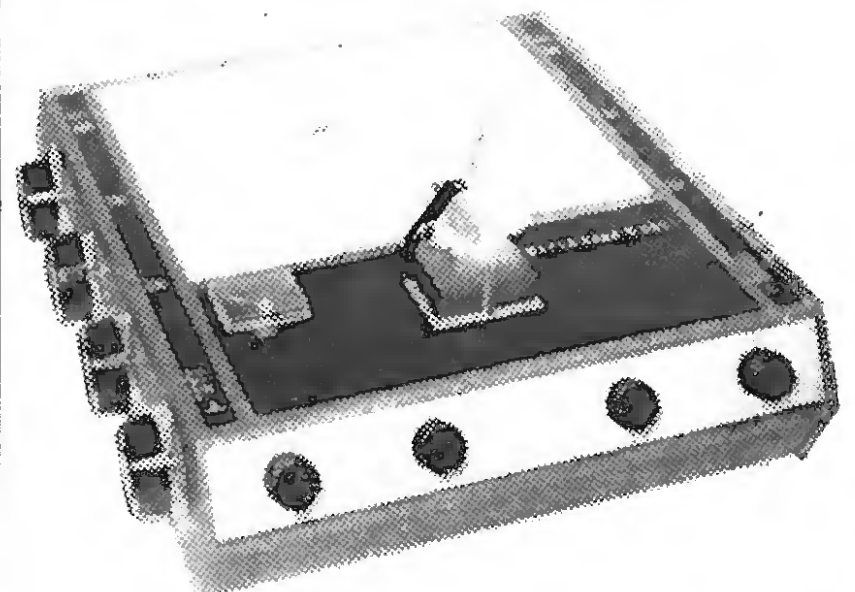

minal measurements to be made if required. At present only 100 kc/s and 1 Mc/s source and detector units are available for the B201, but dummy units may be inserted to permit external equipment to be connected for measurements over the range 100 kc/s to 5 Mc/s. The B201 measures 5 × 12 × 12 in and weighs 12 lb.

The address of the Wayne Kerr Laboratories is Sycamore Grove, New Malden, Surrey.

9WW 305 for further details

R.F. Phase Measuring Instrument

OPERATING in the 15 to 100 Mc/s range, the Teltronics Type PD 200 phase measuring instrument allows accurate phase shift measurement. Basically, the phase detector comprises a dual channel amplifier, which is used to detect by nulling the relative zero phase and amplitude of two input signals. The voltage standing wave ratio is 1.1:1 and gain adjustment is variable from +5 dB to -15 dB; input voltage range is from 250 mV r.m.s. to 500 V d.c.

A series of similar instruments operating up to 2 Gc/s made by the American company Teltronics are also available in the United Kingdom through Microwave Systems Ltd., of 9-10 River Front, Enfield, Middx. The U.K. price of the Model PD 200 is £319.

9WW 306 for further details

Impedance Converter

AN impedance converter that allows low impedance test equipment to be used without loading the apparatus under test is being manufactured by Adams-Norcken Ltd., of Swindon. It comprises a unity-gain amplifier with an input impedance of $8\text{ M}\Omega$ in parallel with 1 pF and an output impedance of 200Ω in series with $50\text{ }\mu\text{F}$. Bandwidth is from 10 c/s to 3 Mc/s and the dynamic range is 4 volts peak-to-peak.

Designated EPO-1, the emitter follower is claimed to have a linearity of better than 1.0%. Other specification details include a noise figure of $20\text{ }\mu\text{V}$ p-to-p when measured with an impedance of $100\text{ k}\Omega$, and less than 0.25% harmonic distortion when measured at 1 volt at 10 kc/s . Two Mallory Type TM175 cells are used to power the probe giving a working life of 80 hours in continuous operation.

As can be seen from the photograph, the probe is quite small and as standard, is fitted with a double screened BNC plug. Different connector and lead arrangements are available to order.

An encapsulated version for either wiring into equipment or for plug-in applications is available. This is known as the EPO-2 and is housed in a $\frac{3}{4}$ -in diameter $\times 1\frac{1}{2}$ -in long aluminium can. Neither batteries nor coupling capacitors are fitted to this unit, which is available with either solder pins for direct connection, Pins for printed circuit board connection, or with valve base pins.

Both of these units are marketed by Kynmore Engineering Co. Ltd., of 19 Buckingham Street, London, W.C.2. The EPO-1 probe costs £18 10s the encapsulated version EPO-2, whatever the pin arrangement, costs £8 12s.

9WW 307 for further details

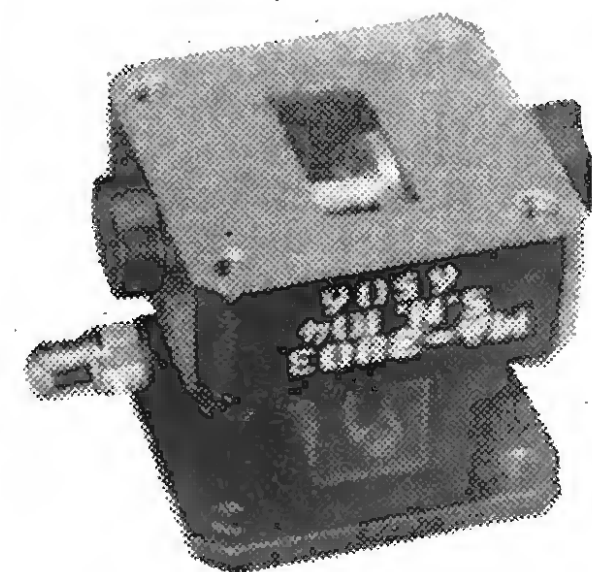
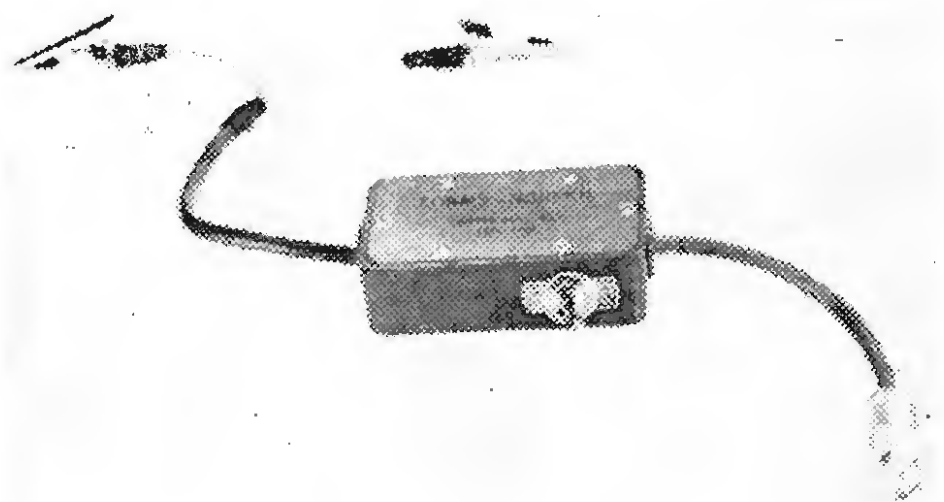

X-Band TR-Limiter

BETTER receiver protection than that given by a TR tube alone, is claimed for the new TR-Limiter Type MA 3803 from Microwave Associates Ltd., of Cradock Road, Luton, Beds. In addition to a TR tube, this device contains a varactor diode, the action of which largely eliminates spike leakage (0.05 ergs) and, the makers claim, removes the major cause for crystal deterioration or burnout.

Compared with the normal TR tube, this unit has a similar insertion loss characteristic (0.8 dB) and has comparable dimensions ($1.55 \times 1.64 \times 1.64$). Other specification details include a centre frequency in the range 8.5 to 9.6 Gc/s with a bandwidth of $\pm 100\text{ Mc/s}$, an average power of 20 watts (peak 10 kW), recovery time of $2\text{ }\mu\text{sec}$, v.s.w.r. of 1.3, noise ratio of 1.15, and a temperature range of -55°C to $+85^\circ\text{C}$.

No additional power other than the "keep alive" electrode supply is needed and the protection claimed—particularly when a radar system is quiescent—is such that the device eliminates the need for a mechanical shutter.

9WW 309 for further details

SUB-MINIATURE MICRO-SWITCH

THE new micro-switch from Plessey, designated Type 18, is particularly suitable for applications where reliability in a small space is of vital importance, such as in aircraft and satellite projects. Although the dimensions of the Type 18 are only $0.35 \times 0.2 \times 0.51$ in, it has a contact rating of 8 amps at either 250 volts a.c. or 30 volts d.c.

This micro-switch is manufactured under licence from the Licon Division of Illinois Tool Works Incorporated, U.S.A., by the Plessey Components Group at New Lane, Havant, Hants. A "butterfly" snap-action mechanism is employed to obtain a good changeover; mechanical life is in excess of 10^6 operations. Good vibration and shock resistance characteristics are claimed for the changeover mechanism. In fact Plessey tests at frequencies from 10 c/s to $2,000\text{ c/s}$ show no contact chatter at 25 g, even with the actuator depressed to within 0.0025 in of trip. Non-stressed ebrillium copper blades and stainless steel coil springs are used in the switching mechanism. The contacts are diffused gold plated.

The case and cover (cut away to show the "butterfly" action in the photograph, which includes a match for comparison—purposes) are moulded in diallyl

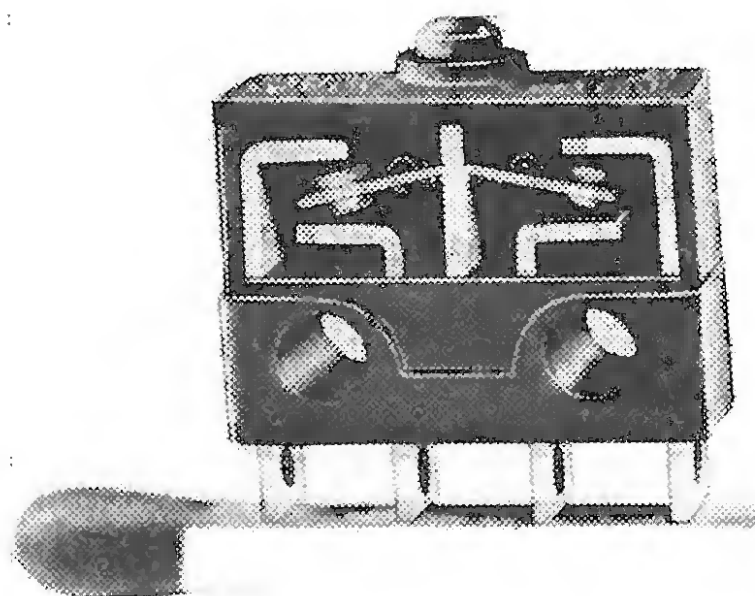

phthalate. The Type 18 may be ganged if more than one circuit is required to be switched from the same actuator. Pre-travel plunger movement is 0.050 in and up to 0.10 in overtravel is permissible.

These switches are available from the Electro-mechanical Division, Plessey-UK Ltd., New Lane, Havant, Hants.

9WW 308 for further details

Low-loss Core Material

A NEW soft magnetic alloy core material, called Satmumetal and made by Telcon Metals, is characterized by low losses (about one quarter of those of silicon iron over the whole operating range of flux density up to 13,000 gauss) and a low magnetizing force requirement—again about one quarter of that for silicon iron. The magnetization curve extends beyond that of normal Mumetal to a flux density of 15,000 gauss. Permeability, varying with magnetizing force, ranges from an initial 40,000 to a maximum 250,000. Coercive force is 0.025 oersteds and remanence is 7,000 gauss. The new material, which at present is only in pilot production, is available in the form of 0.004-in thick tape of varying widths, for winding into toroidal cores.

9WW 310 for further details

Compact Silicon Bridge Rectifier

MEASURING only 12×10×7 mm, the new silicon bridge rectifier offered by Mullard's has an input rating of 42 volts r.m.s. and will provide a rectified output of up to 50 volts at 0.5 amps. This encapsulated device has been designed for

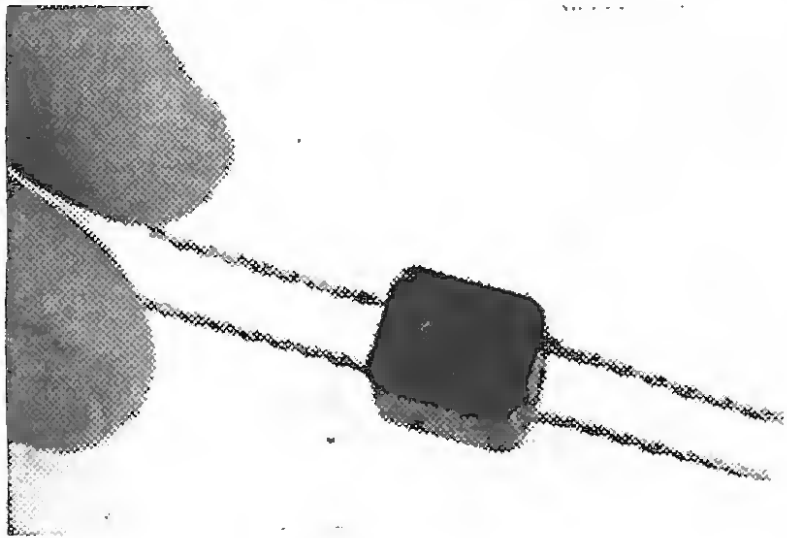

use in the power supply sections of mains-operated radiograms, record players and tape recorders. The peak surge current for this bridge rectifier assembly, designated BY122, is 25 amps. 9WW 311 for further details

Neon Indicators

THE number of high-intensity "Bright-life" neon indicators made by West Hyde Developments Ltd., of 30 High Street, Northwood, Middx., has been considerably increased and now includes units designed for $\frac{3}{8}$ - and $\frac{1}{2}$ -in hole mounting.

Those requiring $\frac{3}{8}$ -in panel holes are made from polypropylene and the larger units are moulded in polycarbonate, a material which gives higher light transmission. Both types of material incidentally give sufficient glow from the rear to warn that equipment is live.

Three styles are available in each type of material with either clear, amber or red glow. The styles being dome, top-hat and square cap. Mounting is by means of a spring clip used to secure the indicator from the rear. Four other items complete the range: a neon, a neon with dropping resistor, a base with lead-out wires, and a neon with dropping resistor on a base.

Models are available to operate in the following ranges: 95 to 150, 160 to 260, and 270 to 500 volts a.c. or d.c. The average life of these indicators is quoted as 25,000 hours. Either six- or thirty-inch leads can be supplied.

9WW 312 for further details

PHOTO-ELECTRIC EQUIPMENT

ABLE to detect objects as thin as $\frac{1}{16}$ in over distances of four feet, the new P 15 equipment being made by the industrial systems division of Electronic Machine Control Ltd. should find many applications in industry. As the illustration shows the equipment is quite small through the use of transistors.

The output of the unit when used in straightforward industrial applications, such as batchcounting, is sufficient to drive any counter directly without intermediate relays. However, for controlling external devices requiring relatively high currents—up to five amps, non-inductive—a changeover relay is provided in the standard equipment. A time delay can be incorporated if required.

This equipment is suitable for direct or reflected-light applications. Mounting clamps are available which allow the transmitting and receiving heads to be

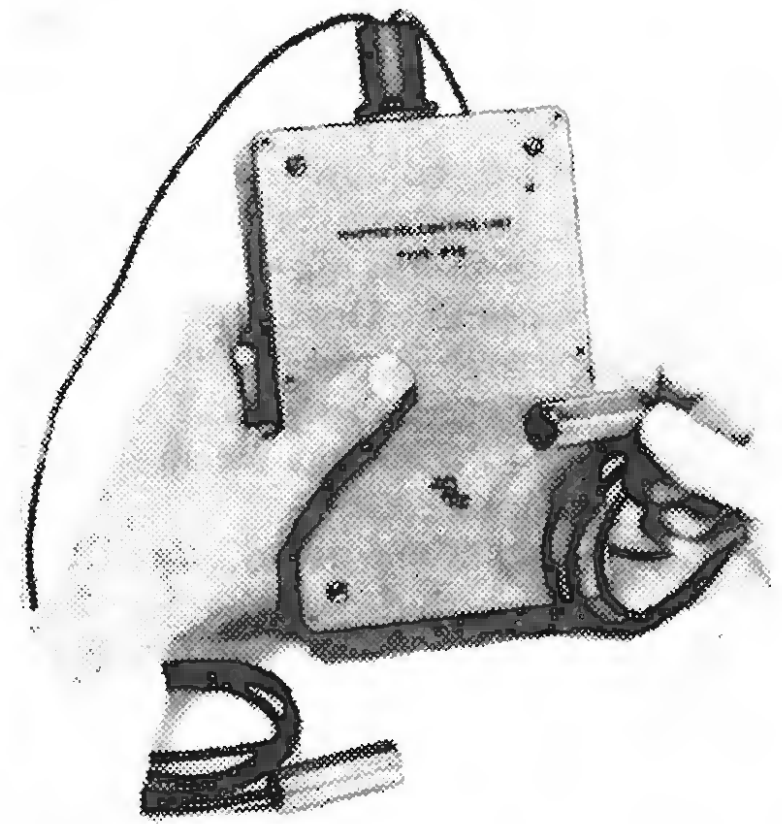

adjusted to give the correct angle of incidence for any reflected light arrangement. The P 15 will operate from any 110 V or 200-250 V a.c. supply.

The ex works price of the P 15 is £22 10s and the company's address is Willow Lane, Mitcham, Surrey. 9WW 313 for further details

Interpolated Data and Speech Transmission

APPARATUS that allows privately leased (two-pair) telephone lines to be used for the transmission of data while the lines are in use for the transmission of speech is being manufactured by the Integrated Electronics Systems Division of Standard Telephones and Cables Ltd., of Enfield, Middx.

According to tests undertaken by the Standard Telecommunication Laboratories, only 32% of the total transmission time of two-pair circuits is used in average speech communications. Most of the wastage (50% of the time) is due, of course, to the fact that only one direction is used at a time. The remaining

18% has been shown to be through gaps and pauses in conversation.

All but a few per cent of this unused time is utilized by the IDAST (Interpolated Data And Speech Transmission) system for the transmission of data. A circuit transmission efficiency of approximately 96% is quoted.

In order to be able to observe and act upon the quiet periods, the input speech is delayed, up to a maximum of 1/5 second, while pulses are generated for marking the beginning and end of the forthcoming speech period. In addition to this function, the generated pulses are used to switch either the data or speech on to the outgoing line. A tone is sent with the information to provide the necessary synchronization at the receiving end, where the incoming signal is

applied to parallel switch units, which head data and speech channels. This tone, which is transmitted only when speech is being sent, opens the speech channel and isolates the data channel. It can also be used to generate command signals for the data receiving equipment should this facility be required. A bandpass filter subsequently removes the tone from the speech.

9WW 314 for further details

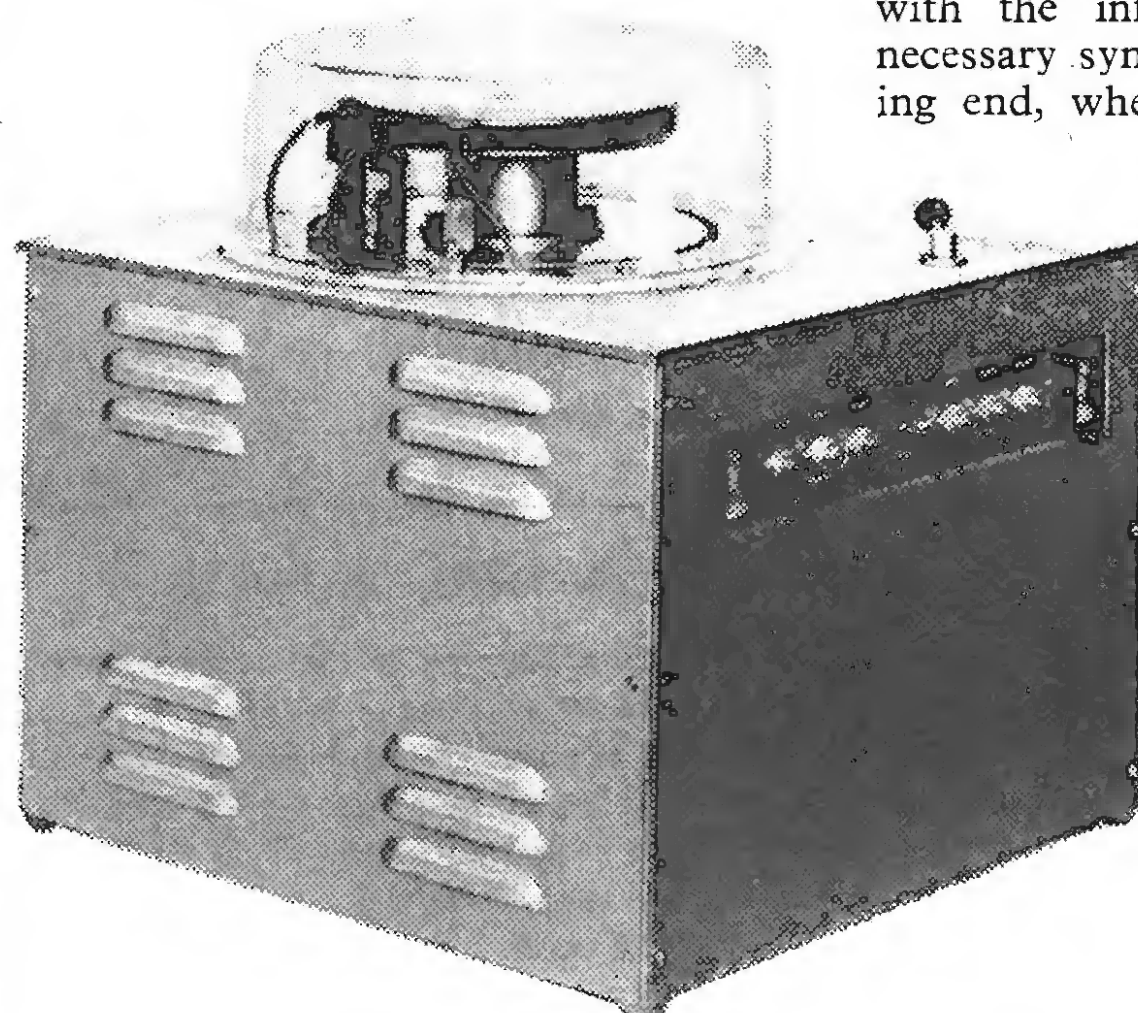

Closed-circuit TV Over Telephone Lines

A VIDEO intercommunication system that utilizes standard two-pair telephone lines is being offered by the Multitone Electric Company. This system, developed in conjunction with Visual Engineers Ltd., employs Grundig line amplifiers to make up for the limitations of telephone lines.

Two line amplifiers are required for a simple camera and monitor installation for distances of up to 2,500 metres. At the transmitting end, the associated line amplifier converts the asymmetrical video signal to a symmetrical one and also amplifies parts of the video signal to compensate for distortion and exponential cable losses. At the receiving end, a line amplifier is used to return the symmetrical signal to an asymmetrical one and also to further compensate for cable losses and correct any distortions.

The actual amplifiers in the Multitone system are designed to compensate for cable losses of up to 10 Mc/s, mak-

ing the system suitable for high-definition applications. Without the use of repeaters, Multitone claim that satisfactory pictures of moving subjects can be obtained over distances of 2,500 metres, and that a complete system can be remotely switched, through an automatic cross-bar telephone exchange, to allow any camera to be connected to any monitor in a private telephone circuit. With the use of repeaters, distances may be doubled.

The Multitone Sinus audio intercommunications equipment, which allows "hands-free conversation" and has been on the market for some time, has been integrated with the video system to allow a number of people to talk at the same time whilst watching a single picture.

The approximate prices of the various units are: monitors £250, camera heads (less lenses) £250, control units £250 and line amplifiers £200.

9WW 315 for further details

Audio Mixer Unit

DESIGNED for use with a wide variety of amplifiers, tape recorders and other signal sources such as dynamic and crystal microphones and radio tuners, is the Heathkit Model TM-1 mixer unit. Two high sensitivity and high impedance channels and two of lower sensitivity and input impedance are provided on this transistor mixer. Each channel has its own, continuously variable, level control and when not in use is automatically earthed when the input plug is removed. A master volume control is provided.

The sensitivities, for an output of 200 mV r.m.s. are as follows: Channel 1, 1.5 mV with 1 M Ω input impedance and 4.5 mV with a nominal 2.5 M Ω input impedance (in the "XTAL" pickup position); Channel 2, 1.5 mV at 1 M Ω ; and Channels 3 & 4, 180 mV at 250 k Ω .

At full output frequency response is within ± 3 dB from 15 c/s to 30 kc/s and the distortion is less than 0.2%.

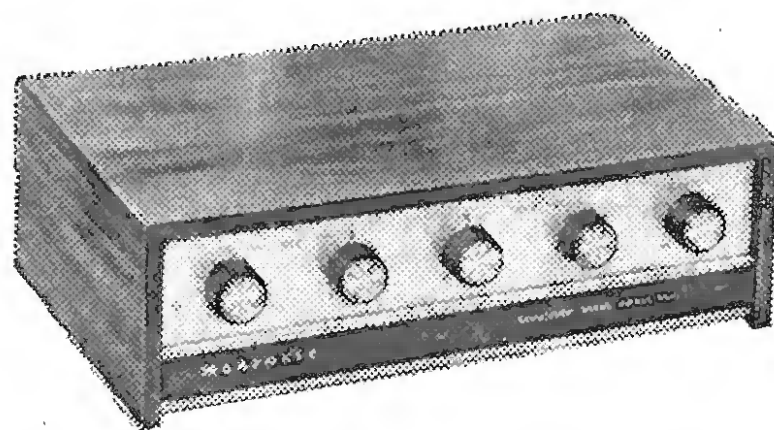

A music/speech switch, which in the speech position attenuates frequencies below 150 c/s, is fitted and has been found to be of benefit in public address applications where low frequencies often cause "boom" to occur. The power consumption at line voltage—9 volts d.c.—is approximately 6 mA. Dimensions are $3\frac{3}{4} \times 11\frac{1}{8} \times 7\frac{1}{2}$ in and weight is 4 $\frac{1}{2}$ lb.

In kit form the price of the Model TM-1 is £11 16s 6d. Assembled and tested, it is available from Daystrom Ltd., of Gloucester, priced £16 17s 6d.

9WW 316 for further details

INFORMATION SERVICE FOR PROFESSIONAL READERS

To expedite requests for further information on products appearing in the editorial and advertisement pages of *Wireless World* each month, a sheet of reader service cards is included in this issue. The cards will be found between advertisement pages 16 and 19.

We invite readers to make use of these cards for all inquiries dealing with specific products. Many editorial items and all advertisements are coded with a number, prefixed by 9WW, and it is then necessary only to enter the number(s) on the card.

Postage is free in the U.K. but cards must be stamped if posted overseas. This service will enable professional readers to obtain the additional information they require quickly and easily.

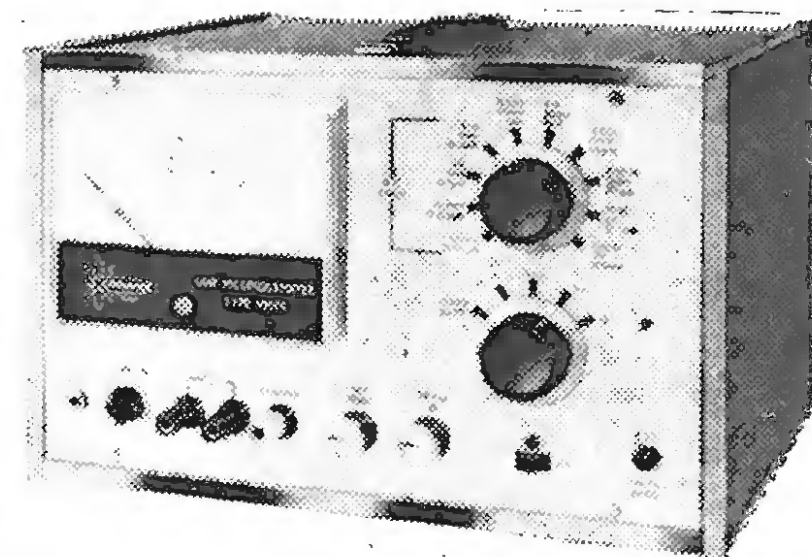

U.H.F. MILLIVOLTMETER

A VERSATILE battery-operated millivoltmeter is announced by Advance Electronics Ltd., of Roebuck Road, Hainault, Ilford, Essex. This instrument, designated VM79, has six a.c. ranges covering 10 mV to 3 V f.s.d. and is suitable for use from 100 kc/s to 1 Gc/s.

Ten ranges are provided for d.c. measurement from 10 nA to 300 μ A f.s.d. Resistance measurements (1 Ω to 10 M Ω) can be made on most types of circuitry with this instrument as the polarizing voltage is only 4 volts.

Readings are indicated on a four-inch meter which has separate scales for each facility. Accuracies quoted are as follows: a.c. voltage is $\pm 3\%$ of reading with a v.s.w.r. of 1; $\pm 2\%$ f.s.d. for d.c. voltage measurements; $\pm 3\%$ f.s.d. for direct current measurements; and $\pm 6\%$ (at mid scale) for resistance measurements. Among the accessories is a 50 Ω coaxial T probe (PL60) which will provide a v.s.w.r. of better than 1.2 (unbalanced input) over the frequency range 100 kc/s to 1 Gc/s.

A d.c. output suitable to drive an x-y recorder is provided on this instrument which measures $7\frac{1}{2} \times 11\frac{1}{8} \times 9\frac{1}{2}$ in and weighs 10 $\frac{1}{2}$ lb. The price of the VM79 is £180.

9WW 317 for further details

Potentiometer in TO-5 Case

SINGLE-TURN top adjustment is provided on the new Model T20P trimming potentiometer from Miniature Electronic Components Ltd., of Copse Road, St. John's, Woking, Surrey. Housed in a case with identical dimensions to the TO-5 transistor can, this device has $\frac{1}{2}$ watt rating at 70°C. Resistance values of 50, 100, 200, 500 ohms, 1, 2, 5 and 10 k Ω are available for T20P. Temperature range is from -55°C to $+150^\circ\text{C}$.

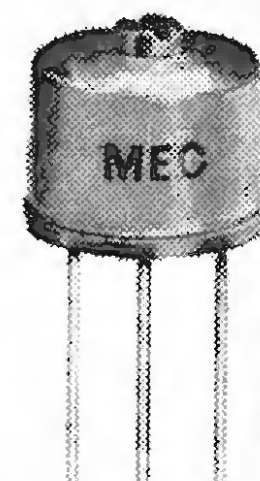

9WW 318 for further details

Elapsed Time Indicator

A RANGE of small electrochemical ampere-hour meters, made by Curtis Instruments (U.S.A.), is now available from Miniature Electronic Components Ltd., of Copse Road, St. John's, Woking, Surrey. The basic model is the 150, which is less than 2 in long and the four versions available allow panel, printed board or socket (polarized or non-polarized) mounting.

A glass capillary tube (0.015 in dia. which allows the device to be used in any attitude due to the high surface tension of mercury) contains two columns of mercury separated by a gap of electrolyte—an aqueous solution of a soluble iodide salt and mercuric iodide. Nickel wire is used for the two electrodes. When a potential is applied across the electrodes, mercury at the anode is transferred to the cathode and as a result the gap moves from cathode to anode. The rate at which the gap

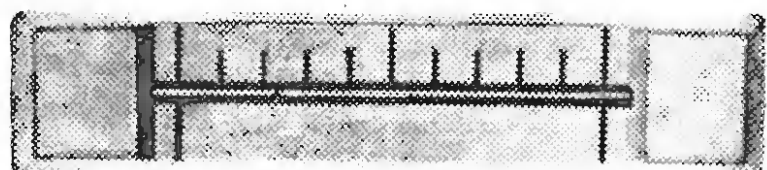

moves is, of course, proportional to the current-time integral and for a constant current the gap displacement is directly proportional to elapsed time.

For elapsed time measurement a series ballast resistor is used to determine the current which should not exceed 5 mA. A ballast resistor of 20-30 times the cell resistance (which is around a few hundred ohms) will swamp the positive temperature coefficient of the cell and reduce dependence on attitude. For a current of about 1 μ A the elapsed time is 10,000 hours and for 5 mA the corresponding time is 2.08 hours. The accuracy is $\pm 2\%$. With a swamp resistor, a current limiting resistor and a shunt Zener diode, the cell may be used with "rough" d.c. or a.c. Temperature range is -20°C to $+90^{\circ}\text{C}$.

The coulometer may, of course, be used as a general purpose integrator and remote readout is possible by capacitive coupling or by optical means.

9WW 319 for further details

"Press-Fit" Terminal

DESIGNED to save chassis area, the new feed-through from Sealectro Ltd. needs only 0.125 in diameter circular area on the chassis, but provides a minimum clearance above and below the chassis of 0.090 in. The body of this one-piece terminal, designated FT-SM-16L24, is of p.t.f.e.

The company's address is Walton Road, Farlington, Portsmouth, Hants.

9WW 320 for further details

WIRELESS WORLD, SEPTEMBER 1965



THE HOUSE OF BULGIN AT YOUR SERVICE

BUSY EXECUTIVES HAVE YOU INSTALLED YOUR DESK-TO-DOOR SIGNAL ?

For really efficient control of visitors/callers, these Kits can only be surpassed by a highly paid personal secretary. Easy to install and very economic, they are the simplest form of office-door communication.

You are always available, and keep in touch with all callers, but maintain complete privacy. The dignified 'May I Enter' system.

Complete in protective Pack.

Mains Kit £6.6s.0d. list.

Battery Kit £5.15s.6d. list.

Subject to Trade Discounts.

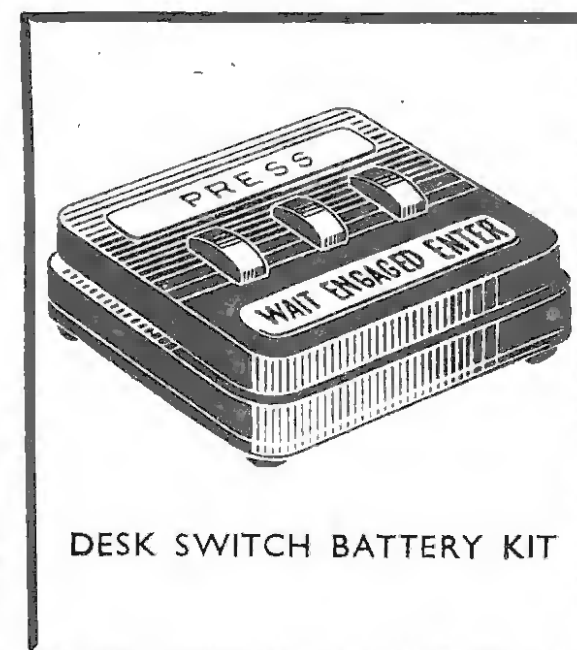
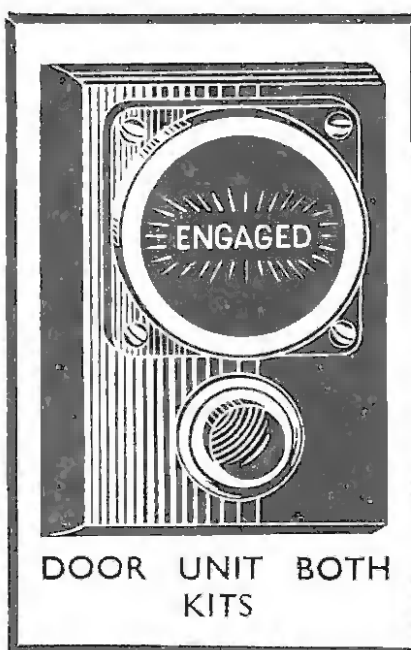

MAINS KIT ALSO CONTAINS: TRANSFORMER · BUZZER · JUNCTION BOX & WIRE
BATTERY KIT ALSO CONTAINS: BUZZER · JUNCTION BOX · WIRE & LIST OF BATTERIES

For full information write, quoting Ref. 1519/C

A. F. BULGIN & CO. LTD.,
Bye Pass Rd., Barking, Essex.
Tel: RIPpleway 5588 (12 lines)

MANUFACTURERS AND SUPPLIERS OF RADIO
AND ELECTRONIC COMPONENTS TO

ADMIRALTY	MINISTRY OF WORKS	B.B.C.
WAR OFFICE	MINISTRY OF AVIATION	G.P.O.
AIR MINISTRY	MINISTRY OF SUPPLY	I.T.A.
HOME OFFICE	RESEARCH ESTABLISHMENTS	N.P.L.
CROWN AGENTS	U.K.A.E.A.	D.S.I.R.

WW-122 FOR FURTHER DETAILS.

A Touch of the Auld Lang Synes

BITTER experience teaches us that we can expect absolutely nothing of a day which starts with getting up in the morning. Armed with this philosophy one can, I find, accept the diurnal ration of slings and arrows of outrageous fortune with a fair percentage of stoicism. But, patently, some days are worse than others, and when a peremptory demand for me to attend upon the person of the Editor (no less) was delivered by express carrier pigeon, it became clear that no good could come of this one. Day, I mean, not pigeon.

To those who have had the good fortune never to have crossed the path of an Editor I should perhaps explain that it is a built-in characteristic of the race that they never demand audience in order to impart good news. The personal confrontation is traditionally reserved for matters of plague and pestilence, and so the sackcloth suit was the only possible choice of garments for the day.

Thus, in the fullness of time, after an initial interrogation at the portals of Dorset House, I was led, by a disdainful commercial equivalent of Jeeves, past cells crammed with galley-slaves until at length we hove to at the outer bastions of the *sanctum sanctorum*. Here I was received by the Editor's ravishing secretary.

Taking a compass bearing on entering the room I struck out for the hinterland and in due course came into sight of a massive desk supporting numerous telephones, with one of which the Editor was heavily entangled. He was, it seemed, at violent variance with a chap by the name of Caxton—a printer, I fancy—and as I made obeisance in the obligatory kneeling posture he slammed down the receiver and, snatching a sjambok, took off down the runway towards the doors without even a parting kick at what must have been, in the circumstances, a provocative target.

I mention all this in some detail to explain how I came to be browsing through vintage volumes of *W.W.* Being thus left *in vacuo* in a highly trepid state I approached the bookshelves which line the room from floor to ceiling, more in the hope of finding spirituous refreshment concealed behind the tomes than of imbibing mental refreshment from their contents*. But no; all were apparently genuine, and thus it was that I found myself in company with the 1913-14 volume of *W.W.*, with nothing better to do than to read it.

Fascinating stuff. In those far off days I found that *W.W.* ran to 108 pages for 3d and that a wireless operator's uniform, complete with gold lace and gold buttons, could have been mine for 60s. Editorially, there were the familiar erudite articles, leavened with features like "Across Bolivia with a Portable set"; but would you expect to find poems? And not only did the readers get the muse for their thruppence, but, believe it or not, a cliff-hanger serial as well.

Yes, a genuine cliff-hanger. Technically slanted, of course. The hero was Charles, a vicar's son, who had invented a wireless-controlled airship complete with death-ray guns. Charles' other hobby was a girl-friend, the Squire's daughter (occasionally referred to in the narrative as Charles' lover, but not, it is to be trusted, in the modern connotation. Not in the vicarage, surely?). Gwen (that's the girl friend, familiarly known to Charles as "chicko") is

* Judging from his description I think he must have found it.—ED.

described as "a bright intelligent girl, secretly a member of the Fabian Society." A member of that institution she might have been (and after all, every silver lining has its dark cloud), but the "bright and intelligent" bit is suspect, since she persuades Charles to let her have a go at the controls and promptly graunches the prototype airship straight into the potting shed.

Other *dramatis personae* include Doss and Suk (sic) a brace of unwashed pedlars, described as being "for ever on the prowl," and M. Dupont and Herr Buelner who are—guess what? That's right; secret agents for a foreign power.

I can't tell you all the ramifications of the plot, except to say that in the end Gwen atones by taking over the control tower and knocking out the entire invading German air force by radio control, deputising for Charles who had inconsiderately contracted a nervous breakdown at the critical hour when England had need of him. True love wins through and in the final scene we find Charles and Gwen abandoning radio control and going over to manual as they walk down the aisle together.

And when you come to think of it, and considering that World War I hadn't started, that story wasn't at all a bad forecast of what was to happen in 1940, if you substitute radar control for radio.

Letters to the Editor were mostly in the form of queries to which a reply was given, and some of these were pretty terse. One hapless correspondent, identified by the initials H. L. N., had his letter held up as a horrible example to others, and was told, *inter alia*, "... You ask too much . . . a full answer would approximate to the size and value of a text-book You are infinitely too vague Half your troubles would be removed if you would take the advice we have repeated over and over again—USE A WAVEMETER You have no possible right to use gas pipes as an earth and if you persist we run the risk of never hearing from you again"

Which just shows what a superman an Editor must be. We weaker vessels would have encouraged the impossible H.L.N. to make his earth connection on to as many gas pipes as he could find . . . "Excellent results are obtained by perforating the main in one or two places and soldering the lead into position with the aid of a blow torch . . ." But not the Editor. He knows that H. L. N. is the bed of nails which an inscrutable Providence has given him to lie upon, and accordingly he goes to the utmost lengths to keep the points sharpened. Of such stuff are demi-gods made.

To those Doubting Thomases who think that I have been making this up I extend my forgiveness and commend them to the library of the British Museum. And in browsing through the volumes, look also at the technical articles therein, and you may, like me, come to the conclusion that the old-timers were not nearly so far back into the Flintstone era as we are prone to think. But perhaps more of that another time.

Oh yes—just for the record—it eventually transpired that the Editor (the 1965 edition, I mean, not the 1913 one) hadn't wanted me at all, but had merely demanded to see a certain adjectival vector diagram which was in course of preparation for an article.